

Discovery Marine

Isolating Base



Technical data

All data is supplied subject to change without notice. Specifications are typical at 24 V, 23°C and 50% RH unless otherwise stated.

<i>Minimum supply voltage in normal operating conditions</i>	17 V dc
<i>Maximum supply voltage</i>	28 V dc plus 9 V dc protocol pulses
<i>Isolation indicator</i>	Yellow LED, lit continuously in isolation condition
<i>Current consumption</i>	
	at 18 V dc 23 µA
	at 28 V dc 43 µA
	at 18 V dc and adjacent sector isolated 4 mA
<i>Maximum line current</i>	
	non-isolating continuous 1.0 A
	transition into isolation 3.0 A
<i>Operating temperature</i>	-20°C to +60°C
<i>Storage temperature</i>	-30°C to +80°C
<i>Humidity (no condensing or icing)</i>	0% to 95% relative humidity
<i>Standards and approvals</i>	MED, LR and ABS
<i>Approved use</i>	Indoor use only
<i>Dimensions</i>	100 mm diameter x 24 mm height
<i>Weight</i>	100 g
<i>Materials</i>	
	Body White polycarbonate moulding
	Terminals Nickel plated stainless steel

Product Overview

Product	Marine Isolating Base
Part No.	45681-286MAR

Approvals

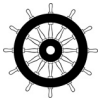

Product Information

The Discovery Marine Isolating Base senses and isolates short circuit faults on XP95 and Discovery loops and spurs.

The Discovery Marine Isolating Base is loop-powered, polarity sensitive and accepts the XPERT 7 address card to set the associated device address.

In short-circuit conditions the integral yellow LED is illuminated. The detector associated with the base remains active under short-circuit conditions. Power and signals to the affected section are restored automatically when the fault is cleared.

Operation

Under normal operating conditions, a low impedance is present between the -IN and -OUT terminals of the base, so that power and signals pass to the last base in line.

If a short-circuit or abnormally low impedance occurs, the fall in voltage is sensed and the base isolates the negative supply in the direction of the fault. The isolated section is tested using a current pulse every five seconds. When the short-circuit is removed, the power will be automatically restored.

If it is a requirement that no device is lost in the event of a single short-circuit, every detector should be fitted to an isolating base.

In applications where it is not necessary to use an isolating base for each detector, up to twenty detectors or equivalent surge

current may be installed between isolating bases. Full details of short-circuit and loop loading can be found in PP2090 - Short Circuit Isolation - available from www.apollo-fire.co.uk

Addressing

Universal address cards, known as XPERT cards, are supplied with all bases. Consult the coding guide in the installation instructions to determine which pips are to be removed from the card to give the correct address.

Lay the card on a flat surface, pips down, insert a screwdriver into the slot on the reverse of the pip to be removed and give a firm twist.

When the card is coded insert it into the slot in the side of the appropriate base making sure that the card locks itself into place. As a detector is inserted into the base the remaining pips operate the address buttons on the detector and the detector electronics read the address. An anti-tamper screw in the lid locks the detector to the mounting base.

Discovery Marine Isolating Base - schematic wiring diagram

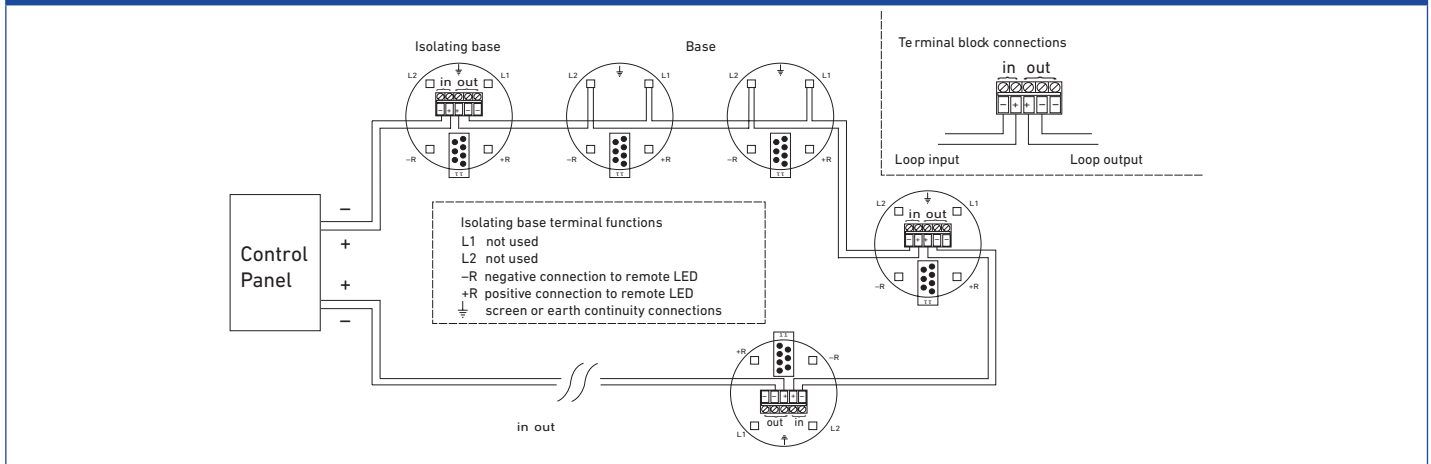

Protocol compatibility

The Discovery Marine Isolating Base is intended for use with equipment using the Apollo XP95 and Discovery communication protocols.

EMC Directive 2014/30/EU

The Discovery Marine Isolating Base complies with the essential requirements of the EMC Directive 2014/30/EU, provided that it is used as described in this data sheet.

A copy of the Declaration of Conformity is available from www.apollo-fire.co.uk.

Conformity of the Discovery Marine Isolating Base with the EMC Directive, does not confer compliance with the directive on any apparatus or systems connected to it.

Construction Products Regulation 305/2011/EU

The Discovery Marine Isolating Base complies with the essential requirements of the Construction Products Regulation 305/2011/EU.

A copy of the Declaration of Performance is available from www.apollo-fire.co.uk.

Marine Equipment Directive 2014/90/EU

The Discovery Marine Isolating Base complies with the essential requirements of the Marine Equipment Directive 2014/90/EU.

Short-circuit Isolation

in Addressable Fire Detection and Alarm Systems

The requirement for isolation

Analogue addressable fire detection systems are usually designed as loops, with the connecting wires starting and finishing at the fire control panel. Detection devices, manual call points and interfaces are connected at intervals along the cables. Depending on the national or local regulations, audible and visual alarm devices are connected either to the same loop as the detection devices or via dedicated loops. Spurs may be connected at any point of the loop, either directly from the loop wires or from an interface, subject to national or local regulation.

Short-circuits do not occur very often, but when they do, the consequences can be serious, possibly making the affected loop entirely inoperative. It is for this reason that isolators have been designed and incorporated into various devices that are connected to the loop. The purpose of these isolating circuits is to protect the loop in the event of a short or partial short-circuit by disconnecting the part of the loop where the short-circuit has occurred. When the short-circuit fault has been rectified, the isolating circuitry automatically reconnects the affected section of the loop.

Features of isolating circuits

Isolators are available in different forms:

- As a stand-alone 'isolator' which is fitted onto special detector style 'isolator bases'
- Incorporated into the detector mounting base, known as 'isolating bases'
- Integrated into Apollo devices such as manual call points, audible and visual alarm devices, interfaces or detection devices (see Table 1)

Isolators are intended for use with Apollo systems using XP95®, Discovery® and CoreProtocol®. Isolators are polarity sensitive and switch the negative line of the loop.

Devices including or fitted to isolators remain operative when an adjacent loop section is in the isolated state. The isolated state is normally indicated by a LED illuminated yellow on the device and through the protocol for CoreProtocol systems.

Equivalent Detector Load

The Equivalent Detector Load (EDL) is a rating value attributed to each device on an XP95/Discovery/CoreProtocol loop, which enables consistent and correct design of the system, when Isolators are used.

Apollo isolating circuits allow the connection of between one and 20 detectors (an EDL of 20) between isolators. The 'equivalent load' for Apollo devices is one for most devices. The 'equivalent load' for devices which are greater than one is given in Table 1. The maximum load for a node is an EDL of 20, this is calculated by adding up the EDL for all devices fitted between two isolators.

Operating principles

Under normal operating conditions the isolator provides a low resistance in either direction. If the loop voltage falls to a pre-set level, the isolator will switch from the closed state to the open state in order to isolate the loop 'in' and 'out' lines.

The isolated section is automatically tested with a test current and is re-connected at a pre-set load resistance value (see Table 2).

Isolator type

There are three types of isolator used in Apollo products:

- The original circuit known as 20D, has been in use since the introduction of XP95
- The 20I circuit was developed in order to reduce the test current which is applied to isolated sections of the loop. It reduces the test current by half.
- The 20C isolator is the latest development which performs much like the 20I isolator but with advanced features that allow additional control of the isolator through Apollo CoreProtocol.

Fire control panel compatibility

Fire control panels that are certificated by Apollo are also compatible with Apollo isolators.

CoreProtocol enabled control panels are able to send a command to 20C isolators which will set a switch open (isolated) state. When the command is reset the isolator will autonomously revert to a closed switch state if no short-circuit is present. It is not possible for 20C isolators to be remotely switched from an open switch to a closed switch state.

System design

It is essential that both loop loading and isolator requirements are taken into consideration when designing a fire detection system.

Generally the loop devices are wired in sequence, so the number of devices between isolators should equal an EDL of 20. If a star configuration is used at a node in the system there may be more than one isolator being powered at the same time so 4 EDL should be added to the node for each additional isolator being powered simultaneously.

Apollo offers a software programme with which the loop loading viability of a design can be checked. The LoopCalc programme can be downloaded at www.apollo-fire.co.uk

Note: All detectors and other devices between any two isolators or isolating devices must be in the same fire zone because communications will be lost if a short circuit occurs between isolators. This design consideration may be subject to national or local regulations.

Quick-start process guide

To work out the isolator loading of a loop:

- Identify the devices between each pair of isolators
- Use Table 1 to determine the EDL of each device
Note: If any devices are star connected and include isolators, then add four EDL for each device. Do not include any devices past the isolator in this node.
- Verify that the sum of the EDL values is less than or equal to 20
- Put the full loop configuration into the ApolloLoopCalc tool
- Verify that the LoopCalc tool confirms 'Loop Design Satisfactory'

Table 1: Apollo products

Part No.	Product name	Isolator type and EDL value			
		20D	20I	20C	EDL*
	DIN MCP (PCB Assy 43785-378)			X	1
45681-277, 278	Integrated Base Sounder 55-91dB (with Isolator)	X			2
45681-284	Isolating Base	X			0
45681-286	Marine Isolating Base	X			0
45681-321	Isolating Base	X**			0
45681-330	Sounder Visual Indicator Base 55-91dB (with isolator)		X		1
45681-333	Visual Indicator Base (with Isolator)		X		1
45681-393	Discovery Sounder Visual Indicator Base (with isolator)		X		1
45681-394	Marine Sounder VID Base		X		1
45681-518	Deep Isolator Base used with 55000-001/-005/-009		X		0
45681-700	Discovery Sounder VAD Base (Cat 0)		X		1
45681-702	Discovery Sounder Base (with isolator)		X		1
45681-705	Sounder VAD Base (Cat 0)		X		1
55000-001	Intelligent Open-area Sounder		X		1
55000-005	Intelligent Open-area Sounder Visual Indicator		X		1
55000-009	Intelligent Open-area Visual Indicator		X		1
55000-022/023/024	XP95 Base Mounted Flame Detector				9
55000-182	XP95 Sounder Control Unit – DIN-rail				3
55000-265	XP95 Beam Detector Receiver and Interface				20
55000-266	XP95A Beam Detector Receiver and Interface				20
55000-268	Intelligent Reflective Beam Detector (with isolator)	X			10
55000-268	Intelligent Reflective Beam Detector				10
55000-280/295	XP95 Flame Detector				20
55000-291/292	Multi-tone Open-area Sounder/Visual Indicator				2
55000-278/279	Multi-tone Open-area Sounder				2
55000-274/275	Weatherproof Multi-tone Open-area Sounder				2
55000-293/294	Multi-tone Open-area Sounder/Visual Indicator with Isolator	X			2
55000-296/297	Weatherproof Multi-tone Open-area Sounder/Visual Indicator				2
55000-298/299	Weatherproof Multi-tone Open-area Sounder/Visual Indicator with Isolator		X		2
55000-588	XP95 Input/Output Unit - 3 Channel (with Isolator)	X			7
55000-709	VAD Base (Cat 0)				2
55000-720	Plug in Isolator	X			0

Table 1: Apollo products

Part No.	Product name	Isolator type and EDL value			
		20D	20I	20C	EDL*
55000-721	Marine Plug in Isolator	X			0
55000-740/743	Loop-powered VAD (Cat C - 15m) <i>(must be fitted to an Isolating Base) ***</i>				20
55000-741/744	Loop-powered VAD (Cat W – 6 m) <i>(must be fitted to an Isolating Base to ensure the operation of this device is not affected by short circuits on the loop cabling)</i>				16
55000-742/745	Loop-powered VAD (Cat C - 8 m) <i>(must be fitted to an Isolating Base to ensure the operation of this device is not affected by short circuits on the loop cabling)</i>				12
55000-750	Plug in Isolator (up to Q1 2019)	X**			0
55000-750	Plug in Isolator (from Q1 2019)	X			0
55000-760, 765	XP95 Mini Switch Monitor		X		1
55000-770	Marine DIN Rail Dual Isolator	X			0
55000-773	Marine DIN Rail Zone Monitor Unit	X**			3
55000-775	Marine Mini Switch Monitor		X		1
55000-797	XP95 Mains Input/Output Unit – DIN-rail				4
55000-802	DIN Rail Dual Isolator	X			0
55000-803	XP95 Input/Output Unit – DIN-rail				4
55000-804	XP95 Output Unit – DIN -rail				3
55000-809	XP95 Switch Monitor Plus				3
55000-810	XP95 Switch Monitor				3
55000-812	DIN Rail ZMU	X**			3
55000-813	XP95 Zone Monitor				3
55000-818	XP95 Input/Output Unit				4
55000-819	XP95 Output Unit				3
55000-820	XP95A Switch Monitor Input/Output Unit				4
55000-821	XP95 Switch Monitor Plus – DIN-rail				3
55000-822	XP95 Switch Monitor – DIN rail				3
55000-823	XP95 Sounder Control Unit				3
55000-825	XP95A Sounder Control Module				3
55000-832	XP95 Mini Switch Monitor with interrupt				3
55000-833	XP95 Mini Switch Monitor				1
55000-841	XP95 Switch Monitor Plus (with Isolator)	X			3
55000-843	XP95 Switch Monitor (with Isolator)	X			3
55000-845	XP95 Zone Monitor (with Isolator)	X			3
55000-847	XP95 Input/Output Unit (with Isolator)	X			4
55000-849	XP95 Output Unit (with Isolator)	X			3
55000-852	XP95 Sounder Control Unit (with Isolator)	X			3
55000-875	XP95 Input/Output Unit – Mains switching				4
55100-9XX	XP95 Manual Call Point (with Isolator) - various housings		X		1
58000-005/007	Discovery Open-area Sounder Visual Indicator (with Isolator)		X		1
58000-010/020	Discovery Open-area Voice Sounder (with isolator)		X		1
58000-030	Discovery Open-area Voice Sounder Visual Indicator (with isolator)		X		1
58100-971	Discovery Marine MCP with Isolator		X		1
58100-976	Discovery Waterproof Marine MCP with Isolator		X		1
58100-9XX	Discovery Manual Call Point (with Isolator) - various housings		X		1
58200-976	Discovery Waterproof Marine MCP with Isolator		X		1

***55000-740/743 Loop-powered VAD (Cat C-15m) - **Special Instructions:** Product requires a specialist installation method, please purchase kit - 55000-747APO (C-3-15, red body) or 55000-748APO (C-3-15, white body) and refer to IG:39215-365 for further information.

Table 1: Apollo products

Part No.	Product name	Isolator type and EDL value			
		20D	20I	20C	EDL*
FL5100-600	Soteria Dimension Optical Detector			X	1
FL6100-600	Soteria Dimension Specialist Optical Detector			X	1
SA4700-100	Intelligent Switch Monitor			X	1
SA4700-102	Intelligent Input/Output Unit			X	1
SA4700-103	Intelligent Mains Input/Output Unit			X	2
SA4700-300	Intelligent Switch Monitor - DIN Rail			X	1
SA4700-302	Intelligent Input/Output Unit - DIN-rail			X	1
SA4700-403	Intelligent Mains Input/Output Unit - DIN-rail			X	2
SA5100-400	Soteria Heat Detector (with Isolator)			X	1
SA5150-450	Soteria UL Heat Detector			X	1
SA5150-650	Soteria UL Photoelectric Smoke Detector			X	1
SA5150-750	Soteria UL Multi-Criteria Detector (Photoelectric/Heat)			X	1
SA5100-600	Soteria Optical Detector (with Isolator)			X	1
SA5100-700	Soteria Multi-Sensor Detector (with Isolator)			X	1
SA5100-760	Soteria Multi-Sensor Detector (with Isolator) (Black)			X	1
SA5100-720/710	Soteria Multi-Sensor Dual Optical/Heat Detector			X	1
SA5100-810/820	Soteria Multi-Sensor Tri Sensor Dual Optical/Heat/CO			X	1
SA5300-300	Soteria Base Sounder			X	1
SA5300-320	Soteria Base Visual Indicator (White Flash)			X	1
SA5300-321	Soteria Base Visual Indicator (Red Flash)			X	1
SA5300-350	Soteria Base Sounder Visual Indicator (White Flash)			X	1
SA5300-351	Soteria Base Sounder Visual Indicator (Red Flash)			X	1
SA5500-300	Intelligent Open-Area Sounder (Red Body)			X	1
SA5501-300	Intelligent Open-Area Sounder (White Body)			X	1
SA5501-320	Intelligent Open-Area Visual Indicator (White Flash, White Body)			X	1
SA5501-321	Intelligent Open-Area Visual Indicator (Red Flash, White Body)			X	1
SA5500-350	Intelligent Open-Area Sounder Visual Indicator (White Flash, Red Body)			X	1
SA5501-350	Intelligent Open-Area Sounder Visual Indicator (White Flash, White Body)			X	1
SA5500-351	Intelligent Open-Area Sounder Visual Indicator (Red Flash, Red Body)			X	1
SA5501-351	Intelligent Open-Area Sounder Visual Indicator (Red Flash, White Body)			X	1
SA5500-500	Open Area VAD (White Flash, White Body)			X	1
SA5501-500	Open Area VAD (Red Flash, White Body)			X	1
SA5500-550	Open Area Sounder VAD (White Flash, Red Body)			X	1
SA5501-550	Open Area Sounder VAD (White Flash, White Body)			X	1
SA5500-551	Open Area Sounder VAD (Red Flash, Red Body)			X	1
SA5501-551	Open Area Sounder VAD (Red Flash, White Body)			X	1
SA5900-908	Intelligent Manual Call Point with Isolator			X	1
SA5900-928	Marine Intelligent MCP			X	1
SA7100-100	Intelligent Reflective Beam Detector			X	10
XPA-IN-14007-APO	XPander Loop Interface		X		2

EDL* - Equivalent Detector Load

X** - Early version of the 20D isolator with similar characteristics

Table 2: EN 54-17 parameters

EN 54-17 parameter	Description	Isolator type		
		20D	20I	20C
V _{min}	Loop dc voltage	17 V + 5 V protocol pulses	17 V + 5 V protocol pulses	17 V + 5 V protocol pulses
V _{max}	Loop dc voltage + Pulse V	28 V + 9 V	28 V + 9 V	35 V + 13 V
V _{SO max}	Isolation voltage	14.8 V	14.8 V	15 V
V _{SO min}	Isolation voltage	13.6 V	13.6 V	12.5 V
V _{SC min}	Voltage to de-isolate (on isolated section with test current applied)	12.9 V	12.9 V	12.8 V
V _{SC max}	Voltage to de-isolate (on isolated section with test current applied)	18 V	18 V	19.1 V
I _{C max}	Continuous switch current	1 A	1 A	1 A
I _{S max}	Maximum switch current	3 A	3 A	3 A
I _{L max dc}	Maximum Isolator leakage current (Test Current)	50mA (pulsed)	28.2mA (dc)	33mA (pulsed)
Z _{C max}	Maximum series resistance - switch closed	0.2Ω	0.2Ω	0.1Ω