



Conventional Marine Manual Call Point

FUNCTION

The Conventional Marine Manual Call Point has been designed to operate on conventional marine fire detection systems.

FEATURES

The Manual Call Point has an easily resettable element rather than a break glass. This call point is supplied with a backbox for surface mounting.

It also features a unique 'Plug and Play' installation concept designed specifically to reduce installation time. The call point utilises a terminal block, where all installation cabling is terminated.

The red Manual Call Point is approved to EN54-11 standard and Marine Equipment Directive 96/98/EC.

MECHANICAL CONSTRUCTION

The component parts of the call point are moulded in polycarbonate or ABS, depending on their function.

DIMENSIONS AND WEIGHT

Indoor	93mm x 89mm x 59.5mm	180g
Outdoor	93mm x 97.5mm x 71mm	350g

OPERATING PRINCIPLES

The Manual Call Point consists of a 470Ω resistor in series with a normally open switch contact.



Part nos. 55100-021MAR (Marine Indoor - Red)
55100-022MAR (Marine Outdoor - Red)

The Manual Call Point helps reduce installation time as all the initial installation cabling is wired to a terminal block which connects neatly to the call point.

Once activated, the manual call point can be reset by inserting the test key into the bottom of the unit until the key clicks into position. Remove the test key and push the front cover up until it clicks home.

EMC DIRECTIVE 2004/108/EC

The Manual Call Point complies with the essential requirements of the EMC Directive 2004/108/EC, provided that it is used as described in this PIN sheet.



Overseas offices:
America China Germany Ireland

36 Brookside Road, Havant,
Hampshire, PO9 1JR, UK.

A HALMA COMPANY

Tel: +44 (0)23 9249 2412
Fax: +44 (0)23 9249 2754

Email: sales@apollo-fire.co.uk
Web: www.apollo-fire.co.uk

A copy of the Declaration of Conformity is available from Apollo on request.

Conformity of the Manual Call Point with the EMC Directive does not confer compliance with the directive on any apparatus or systems connected to it.

TECHNICAL DATA

Maximum Supply voltage 30VDC
 Switch Rating 2A

Operating temperature
 Indoor -10°C to +55°C
 Outdoor -25°C to +70°C

Humidity (no condensation) 0-93 ±3%(Ind/Out)

IP rating
 Indoor 24D
 Outdoor 67

Complies with EMC Directive 2004/108/EC
 Complies with EN54-11:2001
 Complies with Marine Equipment Directive 96/98/EC

DIMENSIONAL DRAWING

INDOOR

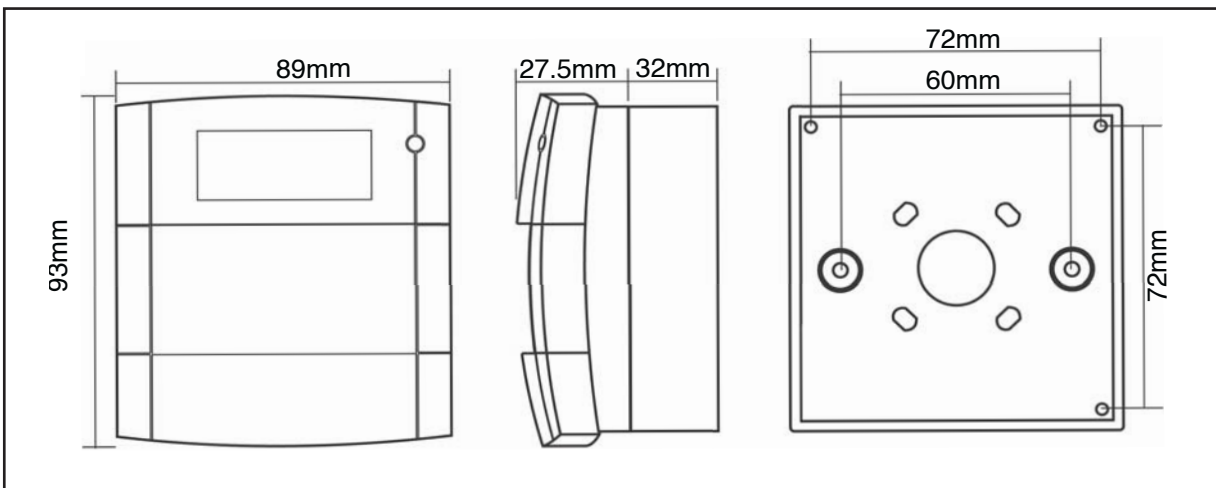

OUTDOOR

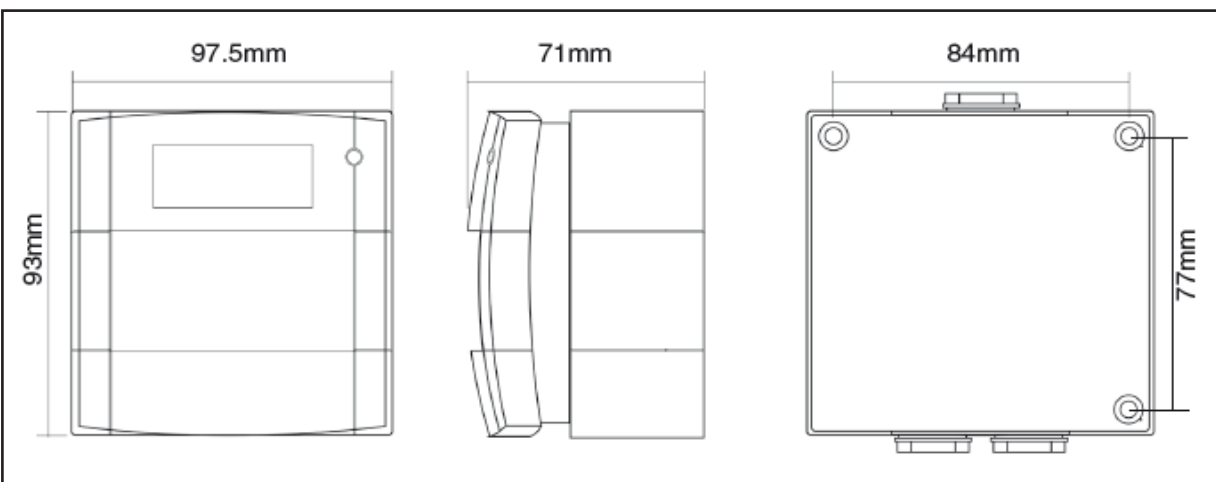



Conventional Marine Indoor Manual Call Point Installation Guide

General

The Conventional Marine Indoor Manual Call Point-Red, part number 55100-021 MAR, model number MCP2A-R470SF-A071-02 is supplied with a backbox for surface mounting. The call point is 'Type A' and is suitable for indoor use only. For flush mounting, a standard electrical outlet box with a minimum depth of 25mm is required.

Installation – General

The installation must conform to BS5839: Part 1 (or applicable local codes).

Installation

1. Fit the backbox (**Fig 1**) to the wall.
2. Run the cables into the backbox and connect them to the terminal block as shown in **Fig 2**. Ensure that functional earth/screen continuity is maintained.
3. Unlock the small front cover by inserting the forked key and pushing it home. Remove key, slide the cover down and remove the deformable element. Connect the terminal block as shown in Fig. 2, secure the call point to the backbox and refit the deformable element as required. Finally, replace the front cover in the reverse order in which it was removed and push it up until it locks.

Transparent Hinged Cover (flip lid)

To provide additional protection against accidental operation of call points, a transparent hinged cover, part no. 26729-152 is available.

To prevent against malicious activations of call points, locking tags are also available, part no. 26729-179.

Please note that the call point does not conform to EN54-11 : 2001 when the hinged cover is secured with the locking tag.

Commissioning

Test each MCP using the test key provided. Ensure the control panel enters the alarm state.

Wiring Details

All wiring terminals accept solid or stranded cables up to 2.5mm².

Technical data

Maximum Voltage	30VDC
Maximum Switching Current	2A
Alarm Resistor	470 Ω / 1W
IP rating	IP24D
Operating Temperature	-10°C to 55°C

Troubleshooting

Before investigating individual units for faults, ensure the system wiring is fault free.

Routine testing

Insert the test key into the hole at the bottom of the call point and push home. Observe routine test requirements as specified in the applicable local codes.

Resetting

After testing, reset the call point by removing the test key and pushing up the front cover until it clicks home.

Important Information

The use of lubricants, cleaning solvents or petroleum based products should be avoided. Do not over tighten fixing screws.

General Fault Finding

Problem	Possible Cause
Control panel reports zone fault	Incorrect zone wiring Detector removed
Control panel reports alarm	EOL device missing or incorrectly fitted MCP not reset Test key not removed
MCP does not activate alarm	Incorrect EOL device Incorrect wiring Incompatible control panel

For further information, please refer to PP2419.

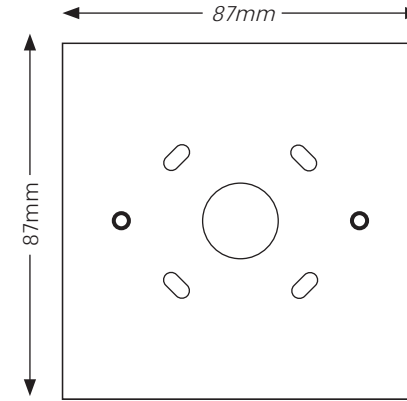

Fig 1 Backbox

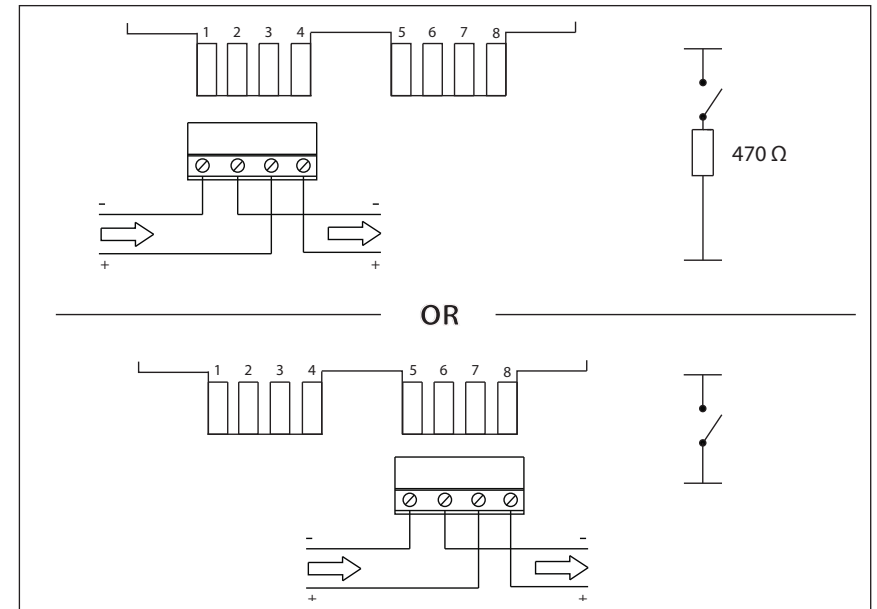

Fig 2 Terminal block connections