

SYNCRO ASM

Voyage Data Recorder Interface

Features

- ▶ NMEA 0183 message format
- ▶ RS485 data connection to VDR
- ▶ Heartbeat sent every 30 seconds
- ▶ Small board profile
- ▶ Panel powered
- ▶ Low current consumption

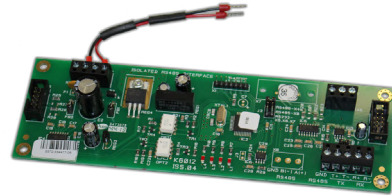

Description

The S737 Voyage Data Recorder (VDR) interface circuit board is installed in close proximity to the Syncro AS Marine fire control panel. It is powered from the panel's Auxiliary 24volt supply output.

When any fire, faults, disablement or panel control operations take place, their details are passed to the VDR equipment over a RS485 2 core shielded cable connection.

The VDR interface uses NMEA 0183 standard message format. The messages will include detection device address, zone and event type, up to 82 characters total

The Syncro AS Marine panel does not monitor the link to the VDR, but sends a "heartbeat" message at 30 second intervals. This heartbeat message allows the VDR system to monitor and report any failures in the data connection

Consideration must be taken as to the loading on the main panel.

Message Format

Sample message from Syncro AS Marine panel
Fire 18/02/09 08:57

SMOKE DETECTOR ADR=120.00 ZoNE 15
Sentence format: \$PKENM, datafield1*hh<cr><lf>
Heartbeat format: \$PKENH,OK*hh<cr><lf>

Data Structure

\$	- Start of message
P	- Proprietary code
KEN	- Manufacturers code (Kentec)
H	- Sentence type H = Heartbeat M = Message Data separator
,	- Data separator
OK	- Text string for heartbeat
*	- Checksum indicator
hh	- 8-bit XOR – checksum in ASCII
<cr><lf>	- End of message

Note: Overall message truncated to 82 characters

Specification

Product code	S737
Supply voltage	21 - 30V DC
Quiescent current consumption	62mA at 24V
Weight	1kg
Communications (panel to S737)	RS232 via ribbon cable
Communications (to VDR)	RS485 two wire
Maximum distance from panel	1.2km (using correct type of cable)
PCB size	190mm x 61mm
Cable capacity	2.5mm per terminal
Operating temperature	-10°C to +50°C
Operating humidity	To 95% (non condensing)

Syncro ASM

Voyage Data Recorder
Hardware Interface (S737)

Marine Fire Control Panel

Man-1125 Issue 03 June 2013

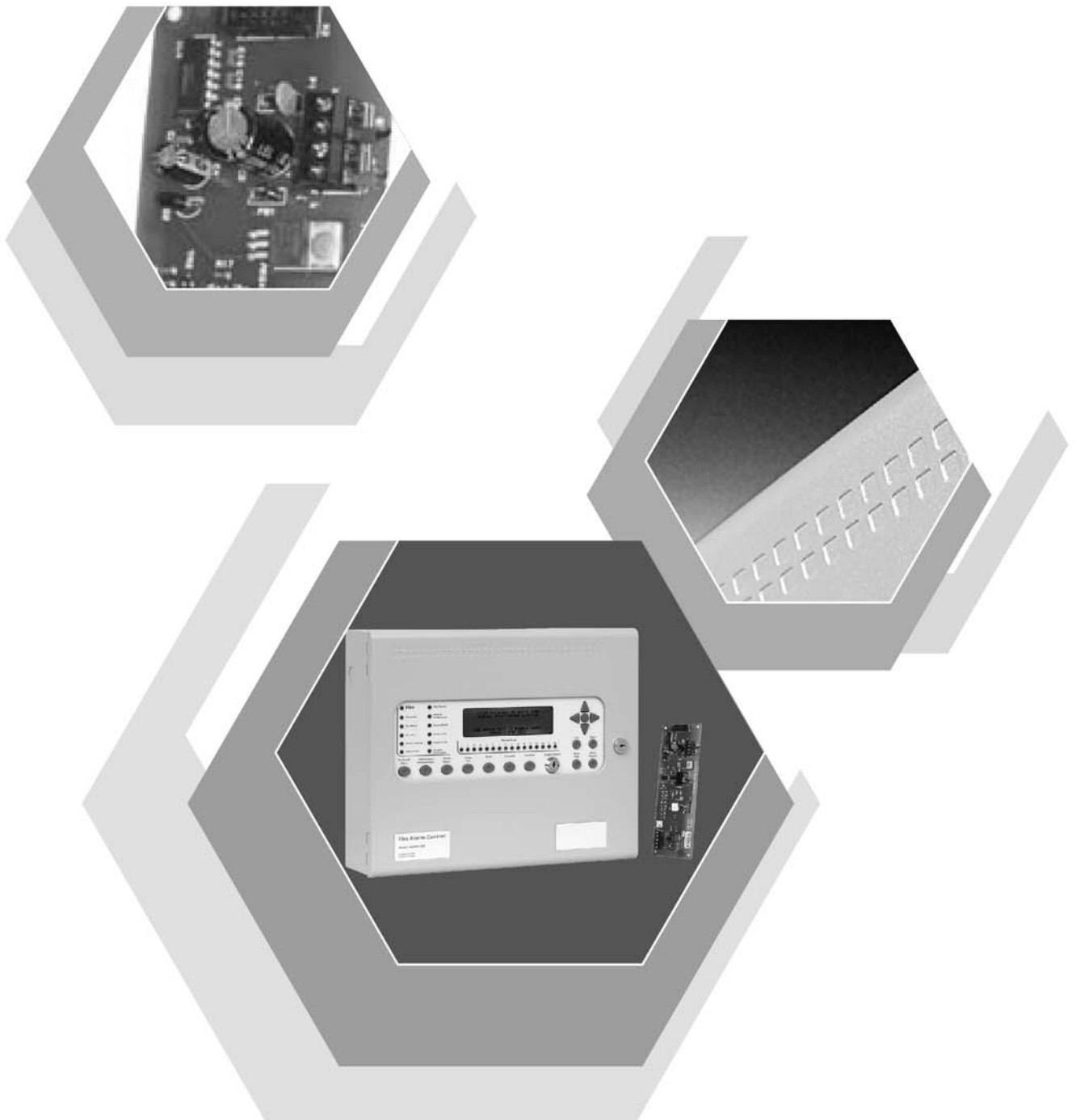

The Kentec Voyage Data Recorder interface allows NMEA 0183 standard messages to be transmitted to the RS485 serial input of a compatible Voyage Data Recorder.

Messages

Messages are sent to the VDR as sentences.

The Syncro ASM fire panel will send data that would normally be sent to the printer abbreviated such that the total message is no greater than 82 characters, including '\$' and CR+LF)

Example message:

```
Fire 18/02/09 08:57
SMOKE DETECTOR ADR=120.00 ZONE 15
```

Sentence format: \$PKENM, datafield1*hh<cr><lf>

Data	Description
\$	Start of message
P	Proprietary code
KEN	Manufacturers code (Kentec)
M	Sentence type (Message)
,	Data separator
Datafeild1	Text string
*	Checksum indicator
hh	8-bit XOR – checksum in ASCII
<cr><lf>	End of message

Heartbeat

The VDR system does not provide any response to the sender so the heartbeat is simply to record that the fire panel is connected. A Heartbeat is sent every 30 seconds.

Heartbeat format: \$PKENH,OK*hh<cr><lf>

Data	Description
\$	Start of message
P	Proprietary code
KEN	Manufacturers code (Kentec)
H	Sentence type (Heartbeat)
,	Data separator
OK	Text string for heartbeat
*	Checksum indicator
hh	8-bit XOR – checksum in ASCII
<cr><lf>	End of message

Hardware

In order to connect the Syncro 'ASM' fire panel to the Voyage Data Recorder, an S737 hardware interface must be connected as shown below.

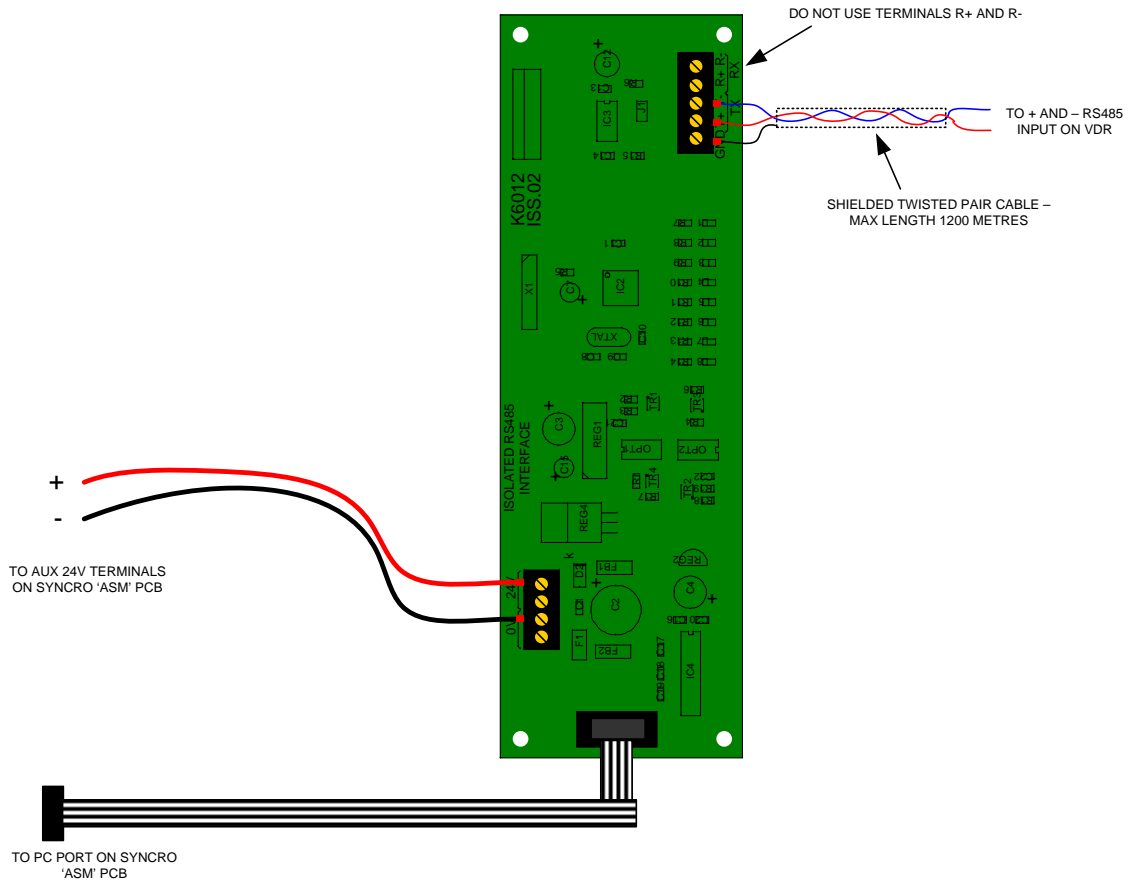

This hardware should be mounted in a suitable enclosure with 3 metres of the Syncro ASM fire control panel.