

Marine Intelligent Base Mounted IR³ Flame Detector



Technical Data

All data is supplied subject to change without notice. Specifications are typical at 24 V, 25°C and 50% RH unless otherwise stated.

Supply voltage	17 - 28 V dc
Digital communication	XP95, Discovery and CoreProtocol compatible
Protocol peak to peak	5 - 9 V
Quiescent current	2.5 mA
Alarm current	4.2 mA
Surge current	9 mA (peak) for 85 ms
Maximum power-up time	4 seconds
Remote output characteristics	Connects to positive line through 4.5 kΩ (5 mA maximum)
Operating range	0.1 m ² n-heptane at 25 m
Sensitivity	Class 1 or 3, EN 54-10
Field of view	90° cone
Spectral response	0.75 to 2.7 μm
Operating temperature	-40°C to +70°C
Storage temperature	-40°C to +70°C
Relative humidity (no condensing or icing)	95% RH
Standards and approvals	MED and ABS
IP rating	designed to IP66
Dimensions	100 mm x 40 mm detector only 100 mm x 48 mm detector and base
Weight	150 g - detector only 210 g - detector and base
Materials:	Housing White flame retardant polycarbonate
	Sensing window 2 mm Float glass
	Terminals Nickel plated stainless steel
Isolator count:	20D 7
	20i 20

Product overview

Product	Marine Intelligent IR ³ Flame Detector
Part No.	55000-029MAR
Digital Communication	XP95, Discovery and CoreProtocol® compatible

Approvals



Product information

The Marine Intelligent Base Mounted Triple Infra -Red (IR³) Flame Detectors are designed to protect indoor areas where open fires may be present.

The detector is sensitive to low frequency, flickering IR radiation emitted by flames during combustion. Since it responds to flickering radiation the detector can operate even if the lens is contaminated by a layer of oil, dust water-vapour or ice.

- Responds to stationary flames with no flicker
- Sensitive to low frequency flickering IR radiation emitted by flames during combustion
- Compact flame detector which fits into Discovery marine bases
- Loop powered
- False alarms due to factors such as flickering sunlight are avoided by a combination of filters and signal processing techniques

Operation

The detector is set to respond to low-frequency radiation at 1 - 15 Hz (0.75 - 2.7 μm) in order to detect all flickering flames, including those invisible to the naked eye, e.g. hydrogen fires.

The detector has three IR sensors that respond to different IR wavelengths in order to discriminate between flames and spurious sources of radiation. False alarms due to factors such as flickering sunlight are avoided by a combination of filters and signal processing techniques.

These detectors are also fast reacting but is also tolerant of fumes, vapours, steam, dust and mist, whilst being unaffected by the phenomena listed above. It may, however, be affected by modulated IR radiation. Triple IR flame detectors are used in waste handling, colour printing and paper manufacturing applications.

* For a full list of applications for Apollo Marine Intelligent Base Mounted Flame Detectors, please refer to PP5010, in this manual or to www.apollo-fire.co.uk

Protocol compatibility

The detectors operate using the XP95 or Discovery digital protocol and are CoreProtocol® compatible.

Protocol usage

Output Bits	
2	LED
1	Test
0	Remote LED
Interrupt	No
Analogue value	
Quiescent	25
Alarm	55 - 64
Fault	4
Input Bits	
2	LED confirmed
1	Test confirmed
0	Remote LED confirmed
Flag settings	
XP95 flag	Yes
Alarm flag	Yes

Electrical description

The Intelligent Base Mounted Flame Detectors are loop-powered and require no external supply. A remote LED alarm indication may be connected to the flame detector.

The field of view for the Intelligent Base Mounted Flame Detectors is shown in Figure 1. The illustration also includes information on the size of fire detectable at various distances.

The flame detectors can also be ceiling mounted positioned above the anticipated flame source or at the centre of the area to be protected, perpendicular to the floor below. If the detector cannot see the whole of the area to be protected, one or more additional detectors may be required. Figure 2 shows the angle of view to help establish the detectors performance. The area of detection is dependent upon the detectors height above the likely source of flame.

The detectors have a 90° conical field of view or 45° either side of the viewing axis centre line. The maximum ceiling height is 20 m. If the detector is perpendicular to the floor and at a height of 10 m, the detector will view a circular floor area below with a 10 m radius (20 m diameter circle).

EMC Directive 2014/30/EU

The Marine Intelligent Base Mounted IR³ Flame Detector complies with the essential requirements of the EMC Directive 2014/30/EU, provided that it is used as described in this datasheet.

A copy of the Declaration of Conformity is available from the Apollo website: www.apollo-fire.co.uk

Conformity of the Marine Intelligent Base Mounted IR³ Flame Detector with the EMC Directive, does not confer compliance with the directive on any apparatus or systems connected to them.

Construction Products Regulation 305/2011/EU

The Marine Intelligent Base Mounted IR³ Flame Detector complies with the essential requirements of the Construction Products Regulation 305/2011/EU.

A copy of the Declaration of Performance is available from the Apollo website: www.apollo-fire.co.uk

Marine Equipment Directive 2014/90/EU

The Marine Intelligent Base Mounted IR³ Flame Detector complies with the essential requirements of the Marine Equipment Directive 2014/90/EU.

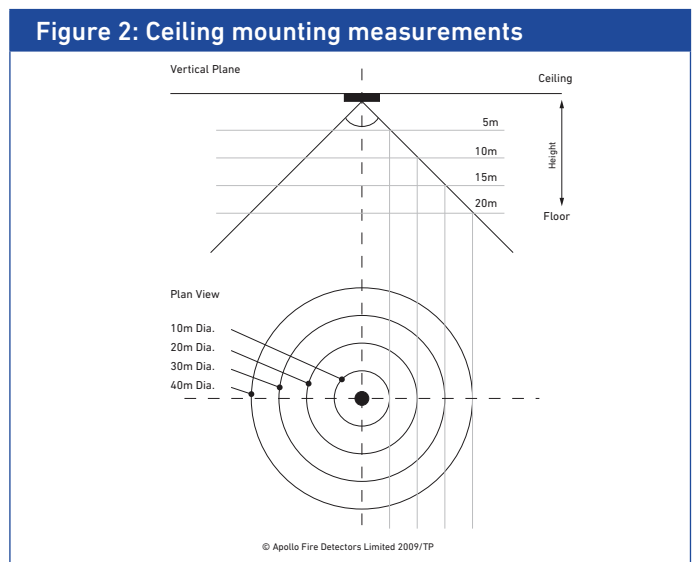
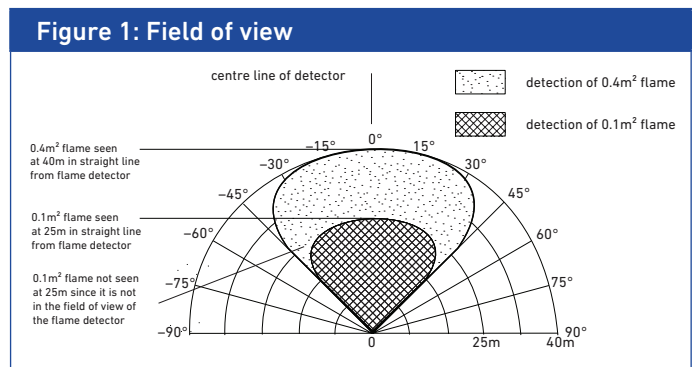

Marine Intelligent Base Mounted Flame Detectors

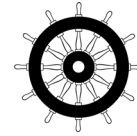

Product overview

Product	Marine Intelligent Base Mounted UV Flame Detector
Part No.	55000-027MAR
Product	Marine Intelligent Base Mounted UV/Dual IR Flame Detector
Part No.	55000-028MAR
Product	Marine Intelligent Base Mounted Triple IR Flame Detector
Part No.	55000-029MAR
Product	Flame detector test unit
Part No.	29600-226
Product	Adjustable mounting bracket including deckhead mounting box
Part No.	29600-458

Technical Data

All data is supplied subject to change without notice. Specifications are typical at 24V, 73°F and 50% RH unless otherwise stated.

	UV	UV/Dual IR	Triple IR
Supply voltage	17 - 28 V dc	17 - 28 V dc	17 - 28 V dc
Protocol peak to peak	5 - 9 V	5 - 9 V	5 - 9 V
Quiescent current	2.3 mA	2.8 mA	2.5 mA
Alarm current	4.2 mA	4.2 mA	4.2 mA
Surge current	9 mA (peak) for 110 ms	9 mA (peak) for 85 ms	9 mA (peak) for 85 ms
Maximum power-up time	4 seconds	4 seconds	4 seconds
Remote output characteristics	Connects to positive line through 4.5 kΩ (5 mA maximum)	Connects to positive line through 4.5 kΩ (5 mA maximum)	Connects to positive line through 4.5 kΩ (5 mA maximum)
Operating range	0.1 m ² n-heptane at 25 m	0.1 m ² n-heptane at 25 m	0.1 m ² n-heptane at 25 m
Sensitivity	Class 1 or 3, EN 54-10	Class 1 or 3, EN 54-10	Class 1 or 3, EN 54-10
Field of view	90° cone	90° cone	90° cone
Spectral response	UV 185 to 260 nm	UV 185 to 260 nm, IR 0.75 to 2.7 μm	0.75 to 2.7 μm
Operating temperature (no condensing or icing)	-40°C to +70°C	-40°C to +70°C	-40°C to +70°C
Storage temperature	-40°C to +85°C	-40°C to +70°C	-40°C to +70°C
Relative humidity	95% non-condensing	95% non-condensing	95% non-condensing
IP rating	IP66	IP66	IP66
Dimensions	100 mm x 40 mm detector only 100 mm x 48 mm detector and base	100 mm x 40 mm detector only 100 mm x 48 mm detector and base	100 mm x 40 mm detector only 100 mm x 48 mm detector and base
Weight	150 g - detector only 210 g - detector and base	150 g - detector only 210 g - detector and base	150 g - detector only 210 g - detector and base
Materials:			
Housing	White polycarbonate, V-0 rated to UL94	White polycarbonate, V-0 rated to UL94	White polycarbonate, V-0 rated to UL94
Sensing window	2 mm Quartz	2 mm Quartz	2 mm Float glass
Terminals	Nickel plated stainless steel	Nickel plated stainless steel	Nickel plated stainless steel
Isolator count:			
20D	7	7	7
20i	20	20	20

36 Brookside Road, Havant | Tel: +44 (0)23 9249 2412 | Email: sales@apollo-fire.com
 Hampshire, PO9 1JR, UK. | Fax: +44 (0)23 9249 2754 | Web: www.apollo-fire.co.uk



A HALMA COMPANY

© Apollo Fire Detectors Limited 2020



Marine Intelligent Base Mounted Flame Detectors

Product information

The Marine Intelligent Base Mounted Flame Detectors are designed to protect areas where open fires may be present.

Marine Intelligent Base Mounted UV Flame Detector

The Marine Intelligent UV Base Mounted Flame Detector is sensitive to ultraviolet (UV) radiation emitted by flames during combustion. Since it requires only UV radiation the detector responds even to stationary flames with no flicker such as cigarette lighters and blue gas flames.

The detector is set to respond to UV radiation (185 - 260 nm) emitted by almost all flames including those invisible to the naked eye, e.g. hydrogen fires.

The detector has a single UV sensor with a narrow spectral response in order to discriminate between flames and most spurious sources of radiation and is designed for use in internal fully enclosed areas.



CAUTION: The detector will also detect electrical discharges from lightning or arc welding.

Marine Intelligent Base Mounted UV/Dual IR Flame Detector

The Marine Intelligent Base Mounted UV/Dual IR Flame Detector is sensitive to UV and low-frequency, flickering infra-red (IR) radiation emitted by flames during combustion. Since it requires both UV and IR radiation the detector can operate in applications where a basic single UV or single IR detector would be inappropriate. The detector is set to respond to UV (185 - 260 nm) and low-frequency, flickering IR (0.75 - 2.7 μm) radiation at 1 - 15 HZ in order to detect all flickering flames, including those invisible to the naked eye, e.g. hydrogen fires. The detector has one UV and two IR sensors responding to different wavelengths in order to discriminate between flames and spurious sources of radiation. False alarms due to electrical discharges or arc welding and flickering sunlight are minimised by combining the UV/IR signals.

Marine Intelligent Triple IR Base Mounted Flame Detector

The detector is sensitive to low frequency, flickering IR radiation emitted by flames during combustion. Since it responds to flickering radiation the detector can operate even if the lens is contaminated by a layer of oil, dust water-vapour or ice. The detector is set to respond to low-frequency radiation at 1 - 15 Hz (0.75 - 2.7 μm) in order to detect all flickering flames, including those invisible to the naked eye, e.g. hydrogen fires. The detector has three IR sensors that respond to different IR wavelengths in order to discriminate between flames and spurious sources of radiation. False alarms due to factors such as flickering sunlight are avoided by a combination of filters and signal processing techniques.

Applications for Marine Intelligent Base Mounted Flame Detectors*

UV

UV detectors are used when detection is required to be unaffected by convection currents, draughts or winds. These include engine rooms in ships, factories affected by draughts or wind and warehouses.

They are fast reacting and respond to a flame more than 25 m away. The UV flame detector is affected by arc welding, electrical sparks, lightning, nuclear radiation and UV light sources. For applications where these phenomena are present a UV flame detector should not be used.

UV/Dual IR

These detectors are not affected by any of the sources mentioned above. They are suitable for use in aircraft hangars, generator rooms (diesel and gas turbines) and paint works.

Triple IR

These detectors are also fast reacting but is also tolerant of fumes, vapours, steam, dust and mist, whilst being unaffected by the phenomena listed above. It may, however, be affected by modulated IR radiation. Triple IR flame detectors are used in waste handling, colour printing and paper manufacturing applications.

* For a full list of applications for Apollo Marine Intelligent Base Mounted Flame Detectors, please refer to PP2409, available on request or from www.apollo-fire.co.uk

Protocol compatibility

The detectors operate with control equipment using the XP95 or Discovery digital protocols.

Protocol usage

Output Bits	
2	LED
1	Test
0	Remote LED
Interrupt	No
Analogue value	
Quiescent	25
Alarm	55 - 64
Fault	4
Input Bits	
2	LED confirmed
1	Test confirmed
0	Remote LED confirmed
Flag settings	
XP95 flag	Yes
Alarm flag	Yes

Electrical considerations

The Marine Intelligent Base Mounted Flame Detectors are loop-powered and require no external supply. A remote LED alarm indication may be connected to the flame detector.

Marine Intelligent Base Mounted Flame Detectors

The field of view for the Marine Intelligent Base Mounted Flame Detectors is shown in Figure 1. The illustration also includes information on the size of fire detectable at various distances.

The flame detectors can also be ceiling mounted positioned above the anticipated flame source or at the centre of the area to be protected, perpendicular to the floor below. If the detector cannot see the whole of the area to be protected, one or more additional detectors may be required. Figure 2 shows the angle of view to help you establish the detectors performance. The area of detection is dependent upon the detectors height above the likely source of flame.

The detectors have a 90° conical field of view or 45° either side of the viewing axis centre line. The maximum ceiling height is 20 m. If the detector is perpendicular to the floor and at a height of 10 m, the detector will view a circular floor area below with a 10 m radius (20 m diameter circle).

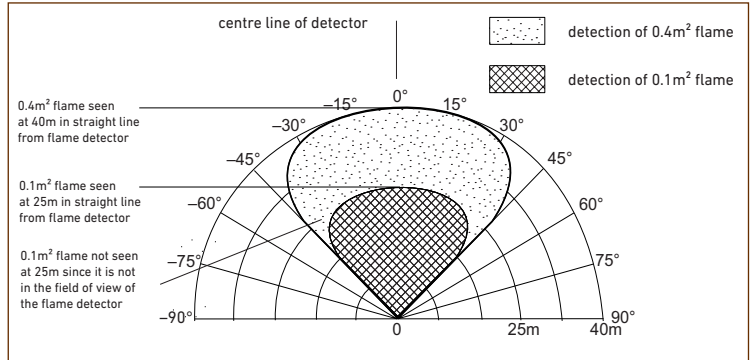

Figure 1: Field of view

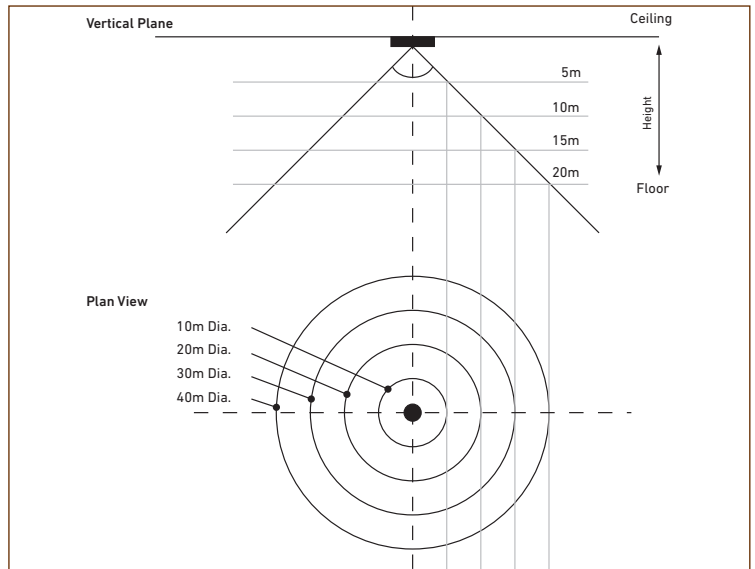

Figure 2: Ceiling mounting measurements

Applications for Marine Intelligent Base Mounted Flame Detectors



Product overview

Product	Marine Intelligent Base Mounted UV Flame Detector
Part No.	55000-027MAR
Product	Marine Intelligent Base Mounted IR² Flame Detector
Part No.	55000-028MAR
Product	Marine Intelligent Base Mounted IR³ Flame Detector
Part No.	55000-029MAR

Applications

Apollo Flame Detectors are designed to protect indoor areas where open fires may be expected.

Ultra Violet (UV)

UV flame detectors are used when detection is required to be unaffected by convection currents, draughts or winds. These include engine rooms in ships, factories and warehouses.

They are fast reacting and respond to a flame more than 25 m away. The UV flame detector is affected by arc welding, electrical sparks, lightning, nuclear radiation and UV light sources. For applications where these phenomena are present a UV flame detector should not be used.

UV/Dual Infra-red (IR)

This detector is not affected by any of the sources mentioned above. They are used in aircraft hangars, generator rooms (diesel and gas turbines), ship's engine rooms and paint works.

Triple IR

The triple IR flame detector is also fast reacting but is also tolerant of fumes, vapours, steam, dust and mist, whilst being unaffected by arc welding, electrical sparks, lightning, nuclear radiation and UV light sources. It may, however, be affected by modulated IR radiation. Triple IR flame detectors are used in waste handling, colour printing and paper manufacturing situations.

Applications	UV	UV/IR ²	IR ³
Aerospace Industry (Hydrogen and Hydrazine fuels)	✓	✓	✓
Aircraft Hangars (under-wing and over-wing protection, military and civil applications)		✓	✓
Automotive (Manufacturing and paint spray booths)		✓	✓
Battery charging areas		✓	✓
Chemical production plants	✓	✓	✓
Chemical stores	✓	✓	✓
Chemical transportation	✓	✓	✓
Compressor stations		✓	✓
Drilling and production platforms		✓	✓
Explosives and Munitions	✓	✓	✓
Ferries and Cargo boats		✓	✓
Fuel loading facilities		✓	✓
Fuel stores	✓	✓	✓
Large industrial warehouses		✓	✓
Large industrial plants	✓		✓
LNG/LPG Processing and storage facilities		✓	✓
Loading racks		✓	✓
Magnesium dry treatment (milling)	✓		
Motor test beds	✓	✓	
Natural gas transfer points		✓	✓
Offshore platforms		✓	✓
Oil and Gas (exploration, production, storage and offloading)		✓	✓
Oil refineries		✓	✓
Onshore (refineries, loading terminals and pipelines)		✓	✓
Paint manufacturing	✓	✓	✓
Paint and Solvent processes	✓	✓	✓
Petrol storage and pump stations		✓	✓
Petrochemical (production, storage and shipping facilities)	✓	✓	✓
Pharmaceutical Industry	✓	✓	✓
Polymers, solvents and glues	✓	✓	✓
Power generation facilities		✓	
Power plants		✓	✓
Printing works	✓	✓	✓
Production facilities			✓
Propane and Butane filling stations		✓	✓
Pump stations	✓	✓	✓
Ships' engine rooms	✓	✓	✓
Tank farms		✓	
Transformer stations		✓	✓
Turbine enclosures		✓	✓
Underground tunnels		✓	✓
Warehouses (storage facilities for flammable materials)	✓	✓	✓
Waste disposal/recycling		✓	✓
Wood product industry	✓		✓
Wood stores			✓

Technical Data

Supply voltage 17–28V DC
 Protocol 5-9V
 Quiescent current 2.5mA
 Alarm current 4.2mA
 Switch-on surge current 9mA (peak) for 85ms
 Power-up time 4 seconds
 Remote output characteristics connects to positive through 4.5KΩ
 (5mA Maximum)

Fire alarm threshold Analogue value 55 returned after 10Hz flame
 flicker for 1.5 seconds
 Operating range 25m for 0.1m² n-heptane fire
 (EN54-10, Class 1)

Operating temperature –40°C to +70°C (no condensation or icing)
 Storage temperature –40°C to +70°C
 Relative humidity 0–95% (no condensation)
 IP rating 66

Housing material white polycarbonate
 V-0 rated to UL94
 Dimensions 100mm diameter
 40mm height, 48mm in base
 Weight 150g detector, 210g in base

Additional Equipment

Portable flame detector test unit Part no. 29600-226
 Adjusted Mounting Bracket Part no. 29600-458



Marine Intelligent Base Mounted IR³ Flame Detector, Installation & Maintenance Guide

General

The Marine Intelligent Base Mounted Triple Infra-red (IR³) Flame Detector, part no 55000-029 MAR, is designed for use where open flaming fires may be expected. It is sensitive to low-frequency, flickering infra-red radiation emitted by flames during combustion. False alarms due to such factors as flickering sunlight are avoided by a combination of filters and signal processing techniques. This product is not compatible with the 45681-321 isolator base.

Response to flames

In quiescent condition, i.e., in the absence of a flame, the detector returns an analogue value of 25. When a flame is visible, the detector signals an alarm by increasing the analogue value returned to 55, usually within 1.5 seconds. The analogue value may continue to rise until it reaches a pre-set maximum of 64.

In the alarm state the Marine IR³ Flame Detector latches for 20 seconds, with the analogue value decreasing to 25 once the flame is no longer detected.

Electrical considerations

The Marine IR³ Flame Detector is loop powered and needs no external supply. It is connected to a control panel using either the XP95[®] or Discovery[®] protocol. A remote LED alarm indicator may be connected to the flame detector.

Sensor window contamination

It is important to keep the sensor window clean and checks should be carried out at regular intervals—determined locally according to the type and degree of contamination encountered—to ensure optimal performance of the flame detector. Although flames can be detected when the window is contaminated, there may be a reduction of sensitivity as shown in the table overleaf.

It is recommended that the Marine IR³ Flame Detector be disabled when the window is being cleaned.

Contaminant	Typical percentage of normal response
Water spray	75
Steam	75
Smoke	75
Oil film	86
Salt water film	86
Dry salt deposits	86

Table 1 Sensor window contamination

Applications for Marine IR³ Flame Detectors

Marine IR³ Flame Detectors are used when detection is required to be unaffected by convection currents, draughts or wind; tolerant of fumes, vapours, steam, dust and mist; responsive to a flame more than 25m away and fast reacting.

Typical applications examples are:

- agriculture – grain and malt processing, animal feed manufacture
- aircraft hangars
- automotive industry – spray booths, parts manufacture
- chipboard and MDF manufacture
- power plants
- printing
- transformer stations

Applications and locations to avoid:

- ambient temperatures above 55°C (continuous)
- sunlight falling directly onto IR optics
- exposure to severe rain and ice
- flickering or moving hot objects
- flood or spot lighting falling directly on IR optics
- large amounts of flickering reflections
- large IR sources above 200°C – heaters, burners, flare stacks
- microwave ovens and dryers
- obstructions to field of view

Functional testing

When polled by a compatible panel or test set, the Marine IR³ Flame Detector, in quiescent condition, should return an analogue value of 25 and input bits set to '0'.

When output bit 2 is set to logic 1 on two or more consecutive pollings, the red LED on the flame detector will illuminate.

When output bit 1 is set to 1 on two or more consecutive pollings the flame detector will perform a self test. It does this by causing internal LEDs to flicker in the field of view of the flame detector, thus simulating the behavior of flames.

When output bit 0 is set to 1 on two or more consecutive pollings the Marine IR³ Flame Detector will switch on a remote LED.

Finally, provided it is safe to do so, carry out a flame test using a flickering flame source, such as a portable bunsen burner. A still, non-flickering flame will not produce a response from the detector.

Maintenance Guide

The Marine IR³ Flame Detector is designed to give years of trouble-free operation with minimal attention. However the periodic maintenance steps listed below are essential to maintain reliable fire protection.

1. Inform all appropriate personnel of intention to work on the flame detector.
2. Disable any automatic systems that may be activated by the flame detector if not required as part of the maintenance check.

Alarms	Extinguishers	Control
Audio/Visual	Gas systems	Plant stops
Auto diallers	Water sprays	Dampers/doors

3. Check that the flame detector's control panel is functioning correctly and shows no faults.
4. Inspect the detector viewing window for any build-up of dust or other contaminants on the optical surface. If necessary clean the optical surface with a cotton wipe and commercial liquid glass cleaner and wipe clean.

The detector specification for performance is with a clean optical sensor window. Contaminants like dust, oil and paint will reduce sensitivity.

5. Ensure the detector still has a clear line of sight of the area it is protecting and no obstacles obstruct its view.
6. Check that the detector is securely fitted.
7. Visually check the exterior of the detector for any mechanical or corrosive damage.
8. Test the operation of the detector with either a portable flame sensor test unit or if practical a flickering yellow flame.
9. Reinstate any automatic system disabled during maintenance.
10. Inform all appropriate personnel on completion of the maintenance work and if necessary record this work.

Sensitivity setting

A sensitivity switch is used to set the sensitivity of the Marine IR³ Flame Detector to Class 1 or Class 3. For most practical purposes the switch should be set to Class 1 (default setting), the sensitivity required to detect flames as described in the section 'Quantities required and positioning of detectors'.

In exceptional cases the Marine IR³ Flame Detector may be set to Class 3 operation in order to avoid nuisance alarms being caused by radiation sources that are close to the detector and can not be moved.

The rotary sensitivity switch is located on the detector rear behind the label. To set to Class 3, rotate the switch 90° clockwise. To return the sensitivity switch to the Class 1 setting, rotate the switch 90° counter clockwise. Reseal label or seal hole with suitable sealant if the sensitivity has been changed.

Installation

The Marine IR³ Flame Detector is mounted on any XP95 or Discovery base and would normally be wall or ceiling mounted preferably on an adjustable bracket to adjust the angle of view.

The standard base mounting is used for horizontal viewing, e.g., along corridors or along the length of industrial processes or vertical viewing inside fume cupboards or over hoppers.

Flame detectors should be fitted to solid walls or rigid constructions that do not move and are not subject to vibration.

The Marine IR³ Flame Detector must be assigned an address by addressing the XPERT card in the usual way. A list of address settings is shown in Table 2.

Wiring

The flame detector has five connections: - Line 1, + Line 2, +Remote, -Remote and functional earth/screen. The connections are accessed by removing the detector from its base. See Fig 4 for connection diagram.

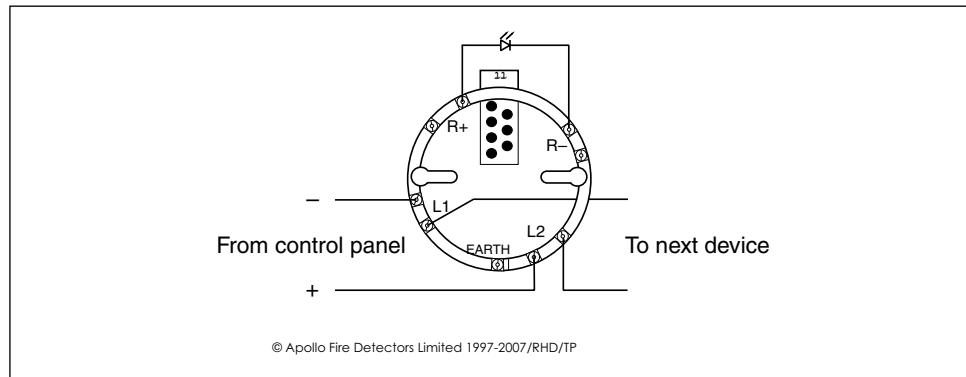

Fig 4 Marine IR³ Flame Detector base connections

Terminal Descriptions

1	+L2	+Line IN and OUT
2	-L1	-Line IN and OUT
3	+R	+Remote LED
4	-R	-Remote LED
5	EARTH	Functional Earth/Screen (Isolated)

Quantities required and positioning of detectors

The number of detectors required and their positioning depends on:

- the anticipated size of the flame
- the distance of the flame from the detector and
- the angle of view of the flame detector

The Marine IR³ Flame Detector is designed to operate to Class 1 performance as defined in EN54: Part 10. The detector will, therefore, detect a yellow flickering flame of approximately 0.1m² or a clear flame of 0.25m² at 25m.

In fact, the flame detector will detect fires at distances of up to 40 metres, but the flame size at such distances needs to be proportionally greater in order to be sure of reliable detection. Thus the yellow flickering flame that can be detected at 25m, provided that its size is not less than 0.1m², will have to be 0.4m² in order to be detected at 40 metres. In a rectangular room the distance from the flame detector to the fire is calculated by the formula:

$$\sqrt{L^2 + W^2 + H^2}$$

In the example shown in Fig 1 the room in which the flame detector is to be installed measures 20m x 10m x 5m; the distance from the detector to the flame will therefore be:

$$\sqrt{20^2 + 10^2 + 5^2}$$

$$= 22.9\text{m}$$

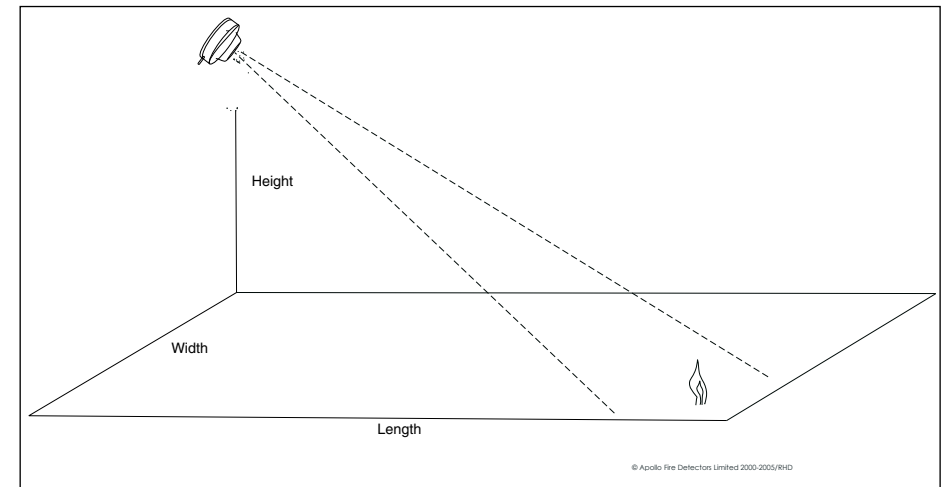

Fig 1 Calculation of distance from detector to flame

The Marine IR³ Flame Detector is often positioned at the perimeter of the room, pointing directly at the area of the anticipated flame or at the centre of the area to be protected. If the detector cannot 'see' the whole of the area to be protected, one or more additional detectors may be required.

The Marine IR³ Flame Detector is not affected by normal light sources but should be positioned so that sunlight does not fall directly onto the viewing window.

The Marine IR³ Flame Detector can also be ceiling mounted, positioned above the anticipated flame source or at the centre of the area to be protected, perpendicular to the floor below. If the detector cannot see the whole of the area to be protected, one or more additional detectors may be required. Refer to the angle of view diagram Fig. 3 to establish the detector performance. The area of detection is dependent on the detectors height above the likely source of flame. The detector has a 90° conical field of view or 45° either side of the viewing axis centre line. If the detector is perpendicular to floor and at a height of 10m then the detector will view a circular floor area below with a 10m radius (20m diameter circle).

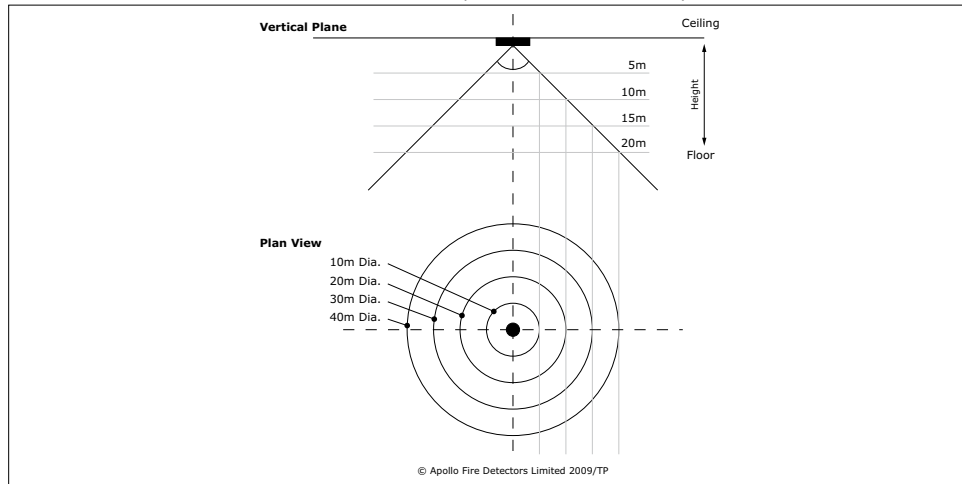

Fig 2 Ceiling mounting example

The Marine IR³ Flame Detector has an angle of view of approximately 90°, as shown in the diagram below.

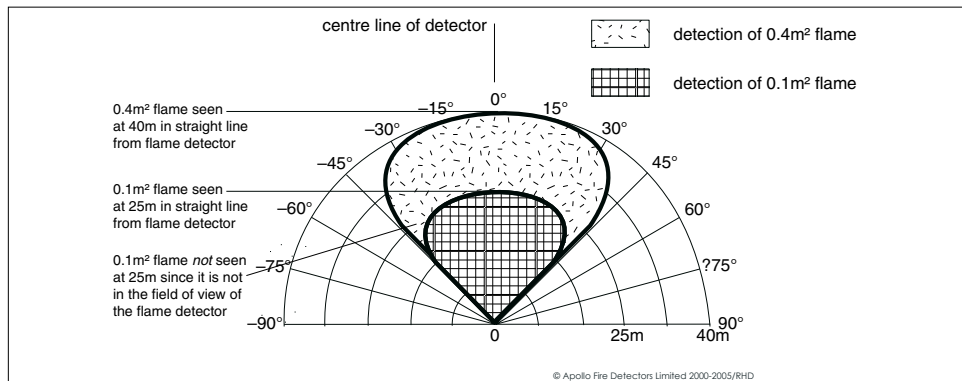

Fig 3 Angle of view of Marine IR³ Flame Detector

To meet the requirements of EN54:10 clause 5.4, were the ratio of the response points $D_{max}:D_{min}$ should not exceed 1.41. The horizontal and vertical viewing angles α_{max} should not exceed ± 32.5

Loop design

The Marine IR³ Flame Detector is powered from the loop; it draws 2.5mA in quiescent state and 4.2mA in alarm. In order to determine the number of flame detectors that can be connected to a given loop, please refer to the Loop Calculation program, which can be downloaded from the Apollo website.

Address Setting

Before installing the Marine IR³ Flame Detector it is necessary to set the address using the XPERT card, select the desired address and remove pips indicated in black. Remove with a small screwdriver.

A complete list of address settings is shown in the table below.

Table 2 XPERT card address settings