

XP95 I.S. Heat Detector



Product overview

Product	I.S. Heat Detector
Part No.	55000-440
Digital communication	XP95, Discovery and CoreProtocol® compatible

Compliance



Product information

The XP95 Intrinsically Safe (I.S.) Heat Detector monitors temperature by using a single thermistor which provides a count output proportional to the external air temperature.

- Ideal for environments that are dirty or smoky under normal circumstances
- Unaffected by wind or atmospheric pressure

Technical data

All data is supplied subject to change without notice. Specifications are typical at 22 V, 25°C and 50% RH unless otherwise stated.

Detection principle	Linear approximation over temperature range 25°C to 90°C
Sensor	Single NTC thermistor
Sampling frequency	Continuous
Sensitivity	25°C to 90°C: 1°C/count -20°C returns 8 counts
Supply Wiring	Two wire supply, polarity sensitive
Terminal functions	L1 Positive supply L2 Negative supply and remote LED negative +R Remote LED positive
Supply voltage	14 V - 22 V dc
Quiescent current	300 µA
Power-up surge current	1 mA
Duration of power-up surge current	0.3 seconds
Max power-up time	4 seconds
Analogue value at 25°C	25 ± 5 counts
Alarm indicator	Red light emitting diode (LED)
Alarm LED current	1 mA
Remote LED current	1 mA (internally limited)
Storage temperature	-30°C to +80°C
Operating temperature	-20°C to +45°C (T5) -20°C to +60°C (T4)
Guaranteed temperature range	-20°C to +60°C
Humidity	0% to 95% RH
Vibration, impact & shock	To EN 54 - 5
IP Rating	IP 44
Standards & approvals	CPR, LPCB, MED, LR, DNV-GL, BV, ABS, BOSEC, VdS, SBSC, RINA, KRS, CCS, IECEx, ATEX
BASEEFA Certificate No.	BAS02ATEX1289X
IECEx Certificate No.	IECExBAS12.0091X
Classification (max ambient)	Ex ia IIC T4 GA (≤ +60°C) Ex ia IIC T5 GA (≤ +45°C)
Dimensions	100mm diameter x 42 mm height
Weight	105 g
Material	Housing: White flame retardant polycarbonate Terminals: Nickel plated stainless steel

Operation

The XP95 I.S. Heat Detector has a common profile with the optical smoke detector but has a low air flow resistance case made of white polycarbonate.

The device monitors heat using a single thermistor network which provides a voltage output proportional to the external air temperature.

Electrical description

The Heat Detector is designed to be connected to a two wire loop circuit carrying both data and a 14 V to 22 V dc supply. The detector is connected to the incoming and outgoing supply via terminals L1 and L2 in the mounting base. The detector is calibrated to give an analogue value of 25 ± 5 counts at 5°C. This value increases with rising temperature. A count of 55 corresponds to the EN alarm sensitivity level.

Remote LED connection

A drive point is provided on the XP95 I.S. Optical Smoke Detector for a remote LED indicator. The indicator must be a standard high-efficiency RED LED and does not require a series limiting resistor since current is limited within the detector to approximately 1 mA. Unlike the standard XP95 range, the remote LED cannot be controlled independently from the integral LED since it is effectively connected in series with the integral LED. The benefit of this configuration is that the illumination of the LED does not increase the current drawn from the loop.

System certification allows for the use of any LED indicator having a suitable surface area between 20 mm² and 10 cm² which covers all commonly used case styles from T1 (3 mm) upwards but would exclude some miniature and surface mounted types. Additional requirements of the certification are that the LED and its terminations must be afforded a degree of protection of at least IP20 and must be segregated from other circuits and conductors as defined in BS EN 60079-14.

The Apollo MiniDisc Remote Indicator, Part No. 53832-070, is suitable using terms X + Y.

EMC Directive 2014/30/EU

The XP95 I.S. Heat Detector complies with the essential requirements of the EMC Directive 2014/30/EU, provided that it is used as described in this datasheet.

A copy of the Declaration of Conformity is available from Apollo upon request.

Conformity of the XP95 I.S. Heat Detector with the EMC Directive, does not confer compliance with the directive on any apparatus or systems connected to it.

Construction Products Regulation (EU) 305/2011

The XP95 I.S. Heat Detector complies with the essential requirements of the Construction Products Regulation (EU) 305/2011.

A copy of the Declaration of Performance is available from Apollo upon request.

Marine Equipment Directive 2014/90/EU

The XP95 I.S. Heat Detector complies with the essential requirements of the Marine Equipment Directive 2014/90/EU.

ATEX Directive 2014/34/EU

The XP95 I.S. Heat Detector complies with the essential requirements of the ATEX Directive 2014/34/EU.

XP95 I.S. Heat Detector sectional diagram

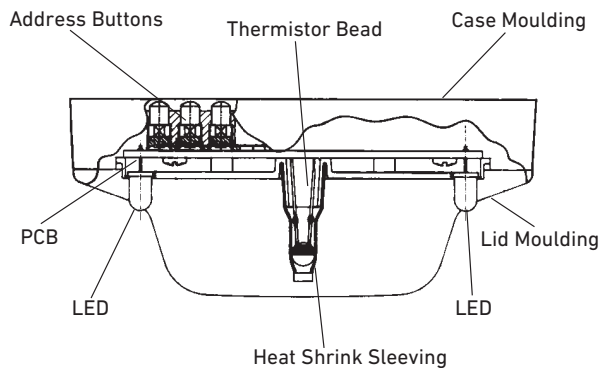

About XP95 I.S.

Introduction to intrinsic safety

There are many places where an explosive mixture of air and gas or vapour is or may be present continuously, intermittently or as a result of an accident. These are defined as hazardous areas by BS EN 60079, the code of practice for installation and maintenance of electrical apparatus in potentially explosive atmospheres.

Hazardous areas are common in petroleum and chemical engineering plants and in factories processing and storing gases, solvents, paints and other volatile substances.

Electrical equipment for use in these areas needs to be designed so that it cannot ignite an explosive mixture, not only in normal operation but also in fault conditions. There are a number of methods available to achieve this, oil-immersion, pressurised apparatus and powder filling, for example, but the two in most common use are flameproof enclosures and intrinsic safety.

Flameproof equipment is contained in a box so strong that an internal explosion will neither damage the box nor be transmitted outside the box. The surface must remain cool enough not to ignite the explosive mixture.

When flameproof equipment is interconnected, flameproof wiring must be used. This method is most valuable when high power levels are unavoidable but is not acceptable for areas in which an explosive gas/air mixture may be continuously present or present for long periods.

For this reason Apollo fire detectors are made intrinsically safe rather than flameproof. Intrinsically safe equipment operates at such low power and with such small amounts of stored energy that it is incapable of causing ignition:

- In normal conditions
- With a single fault (for Ex ib classification)
- With any combination of two faults (for Ex ia classification)

In any of these conditions every component must remain cool enough not to ignite the gases for which it is approved.

Classification of hazardous areas

BS EN 60079-10-1 defines a hazardous area as one in which explosive gas/air mixtures are, or may be expected to be, present in quantities such as to require special precautions for the construction and use of electrical apparatus.

The degree of risk in any area is a function of:

- The probability of an explosive mixture being present
- The type of gas which may be present
- The temperature at which a gas might ignite spontaneously

These are defined in Table 1, Zone Classification, Table 2, Sub-division of Group II Gases.

Table 1: Zone classification

Zone	Definition	Intrinsically safe equipment approval required
0	In which an explosive gas/air mixture is continuously present or present for long periods	Ex ia
1	In which an explosive gas/air mixture is likely to occur in normal operation	Ex ia or Ex ib
2	In which an explosive gas/air mixture is not likely to occur in normal operation and if it occurs will exist only for a short time	Ex ia or Ex ib

Table 2: Subdivision of Group II gases

Zone	Definition	Intrinsically safe equipment approval required
Acetylene	Carbon Disulphide, Hydrogen	IIC
Ethylene	Butadiene, Formaldehyde, Diethyl-ether	IIB or IIC
Propane	Acetaldehyde, Acetone, Benzene, Butane, Ethane, Hexane, Heptane, Kerosene, Naptha, Petroleum, Styrene, Xylene	IIA or IIB or IIC

Related Apollo Product Ranges

Product	Publication Type	PP Number
XP95 Range	Engineering Product Guide	PP1039
	General Sales Brochure	PP1040
XP95 I.S.	Sales Leaflet	PP1094
Orbis I.S.	Engineering Product Guide	PP2147
MiniDisc Remote Indicator	Datasheet	PP2074
Bases and Accessories	Brochure	PP1089
Mounting Accessories	Datasheet	PP5068

XP95 Intrinsically Safe communications protocol

The standard XP95 communications protocol is designed to be very robust and to give the maximum flexibility to designers of loop driver circuits. The current and voltage levels used are chosen to be well above noise levels and to operate in adverse conditions with the minimum of errors. The maximum voltage and current levels used are, however, outside the limits of intrinsically safe (I.S.) systems and it has been necessary to apply lower limiting values for both current and voltage in the I.S. range.

The voltage limitation arises because of the need for safety barriers. The barriers used with Apollo I.S. detectors are rated at 28 volts, the highest rating that is commercially available. These are used to limit the voltage inside the hazardous area to a (practical) maximum of about 26 V dc. Although this is within the standard XP95 protocol specification, it is lower than that provided by most loop drivers.

The safety barrier is also responsible for the current limitation because the 28 V barriers have a series resistance of at least 300 ohms. This resistance results in unacceptable voltage drops if the normal 20 mA current pulses are used. It has therefore been necessary to reduce the amplitude of the current pulses to 10 mA.

XP95 Protocol Translator

In order to enable the use of standard control and indicating equipment in intrinsically safe systems, Apollo has developed a device to 'translate' voltage levels from any loop driver operating within the XP95 limits to levels compatible with the I.S. requirements. The translator also 'boosts' the current pulses returned by the I.S. detectors from 10 mA to 20 mA, thereby ensuring compatibility with standard loop driver thresholds. For more information regarding the XP95 Protocol Translator refer to PP5034.

System design

The design of an intrinsically safe fire detection system should only be undertaken by engineers familiar with codes of practice for detection systems and hazardous area electrical systems. In the UK the relevant standards are BS5839-1 and BS EN 60079-14 respectively.

The fire detection performance of the XP95 I.S. range is the same as that of its standard counterparts. Performance information is given in the XP95 I.S. products data sheets.

The BASEEFA certification of the I.S. devices covers their characteristics as components of an intrinsically safe system and indicates that they can be used with a margin of safety in such systems. The precise way in which the system can be connected and configured is covered by an additional, 'system' certification. The System Diagram, Z20982, see Figure 6, details cable parameters and permissible configurations of detectors, manual call points and safety barriers which are certified by BASEEFA. Any user wishing to install a system outside the parameters given on this system diagram cannot make use of the Apollo certification and should seek independent certification from a competent certification body.

The BASEEFA system Certificate Number is BAS21Y0069 / IECEx BAS21.0014

Any system installed within the parameters specified in Z20982 should be marked in accordance with BS EN 60079-25. The marking should include at least 'Apollo XP95 I.S. Fire Detection System, BASEEFA No BAS21Y0069 / IECEx BAS21.0014

In safe area (standard) applications it will be normal practice to connect the wiring as a loop, with both ends terminated at the

control panel. In the event of an open-circuit fault it is then possible to drive both ends simultaneously. In a hazardous area it is not possible to use a loop configuration because the potential to feed power from each end of the loop would double the available energy in the hazardous area and contravene the energy limitations of the I.S. certification. All XP95 I.S. circuits must therefore be connected as spurs from the safe area loop or as radial connections from the control panel.

It is recommended, for the highest system integrity, that each I.S. circuit be restricted to a single zone and that the connection from the safe area loop to the I.S. spur be protected on each side by XP95 isolators. The DIN-Rail dual isolator (55000-802) is particularly suited to this application. This configuration, shown in Figure 1 will conform fully with the requirements of BS5839-1 and with local codes since a single wiring fault will result in the loss of only one zone of detection.

Figure 1: Schematic wiring diagram of XP95 I.S. circuit to BS5839

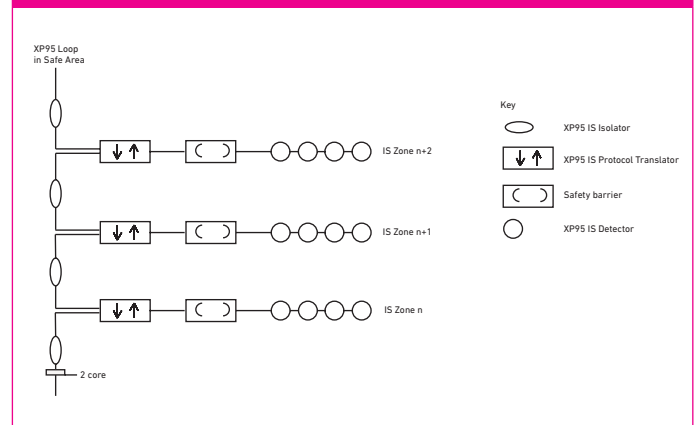

In certain circumstances it may be possible for the simpler configuration, shown in Figure 2 to be used. This arrangement may include single or dual-channel translators, housed, together with the critical wiring, in a robust mechanical housing such as the Apollo DIN-Rail enclosures part no. 29600-239 (1 x I.S. circuit) or part no. 29600-240 (up to 5 x I.S. circuits). For further advice, please contact the Technical Support Team at Apollo.

Figure 2: Schematic wiring diagram of XP95 I.S. circuit using a dual channel protocol translator

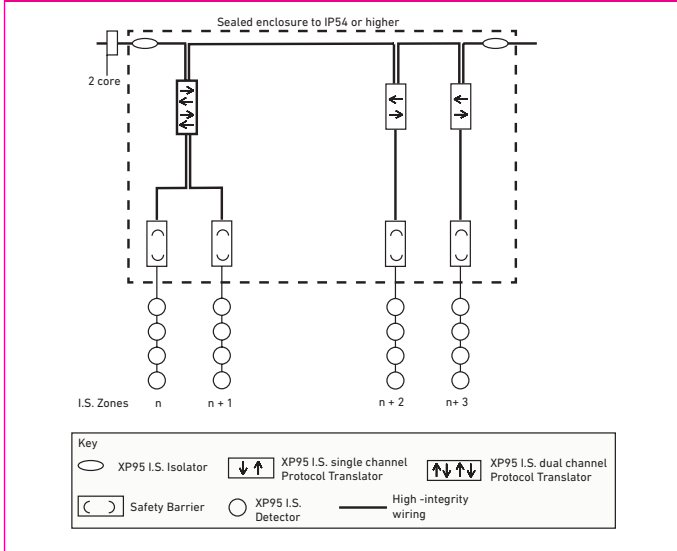
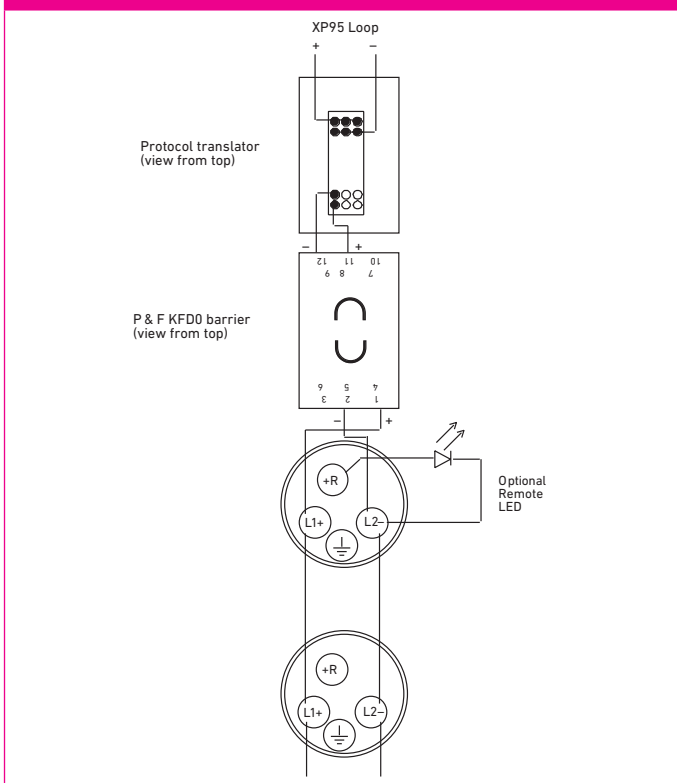

Figure 3: Detail of wiring diagram for XP95 I.S. Zone



Types of safety barriers

The certified system configurations allow for two types of safety barrier, each of which has its own advantages and disadvantages. A brief outline of their characteristics is given below.

Single Channel 28 V/300 Ω Barrier

This is the most basic type of barrier and therefore the lowest in cost. Being passive devices, they also impose the minimum of restrictions on the operation of the fire detectors. Thus, single channel barriers are available either as positive or negative polarity where the polarity refers to the polarity of the applied voltage relative to earth.

The significance of this is that one side of the barrier must be connected to a high-integrity (safety) earth. Although this earth connection has no effect on the operation of the XP95 I.S. devices and is not needed for their correct operation, it may not be acceptable to the operation of the control and indicating equipment. This is particularly true if the control equipment incorporates earth-leakage monitoring and even without this feature the earthing of the loop may cause unwanted cross-talk between loops.

If the earth connection is not acceptable then the isolating barriers should be used.

Galvanically Isolated Barrier

Galvanically isolated barriers (also known as transformer isolated barriers) differ from conventional shunt zener barriers in that they provide electrical isolation between the input (safe area) and the output (hazardous area). This is achieved by the use of a dc converter on the input side which is connected to the hazardous area through a voltage- and power-limiting resistor/zener combination similar to a conventional barrier.

The galvanic isolation technique means that the circuit does not need a high integrity (safety) earth and that the intrinsically safe circuit is fully floating. Earth leakage problems for control and indicating equipment are therefore eliminated if this type of interface is used.

Note: Although the circuit does not require a high-integrity earth, it is permissible to earth either polarity of the hazardous area circuit if required by other system considerations.

Although galvanically isolated barriers are widely used with conventional fire detectors the pulse response of standard products has been too slow to allow their use in analogue addressable systems. Apollo has worked closely with Pepperl + Fuchs in the development of a special galvanically isolated barrier which freely transmits the XP95 protocol pulses without introducing severe voltage drops.

This interface is available as single or dual channel versions and is recommended for any application in which direct earth connections are not acceptable. The Pepperl + Fuchs type numbers are KFD0-CS-Ex1.54 (Apollo part no. 29600-098) and KFD0-CS-Ex2.54 (available from Pepperl + Fuchs) for the single and dual

channel devices respectively. Both versions are BASEEFA certified under Certificate Number BAS00ATEX7087.

The galvanically isolated barrier is a two-wire device which does not need an external power supply. Current drawn from the XP95 loop by the barrier itself is less than 2mA when loaded as specified by the manufacturer. The housing is a DIN-Rail mounting, identical to that used for the protocol translator.

Approved safety barriers

The system certification includes a generic specification for barriers, two additional, individually approved barriers and two transformer isolated current repeaters (galvanic barriers).

The generic specification is:

Any shunt zener diode safety barrier certified by BASEEFA or any EU approved certification body to

E Ex ia IIC

Having the following or lower output parameters:

$$U_z = 28 \text{ V}$$

$$I_{\text{max:out}} = 93.3 \text{ mA}$$

$$W_{\text{max: out}} = 0.67 \text{ W}$$

In any safety barrier used the output current must be limited by a resistor 'R' such that

$$I_{\text{max: out}} = \frac{U_z}{R}$$

Wiring and cable types

It is not permitted to connect more than one circuit in the hazardous area to any one safety barrier and that circuit may not be connected to any other electrical circuit.

Both separate and twin cables may be used. A pair contained in a type 'A' or 'B' multicore cable (as defined in clause 12.2.2 of BS EN 60079-14) may also be used, provided that the peak voltage of any circuit contained within the multicore does not exceed 60 V.

The capacitance and either the inductance or the inductance to resistance (L/R) ratio of the hazardous area cables must not exceed the parameters specified in Table 4. The reason for this is that energy can be stored in a cable and it is necessary to use cable in which energy stored is insufficient to ignite an explosive atmosphere.

To calculate the total capacitance or inductance for the length of cables in the hazardous area, refer to Table 3, which gives typical per kilometre capacitance and inductance for commonly used cables. (*Note: All XP95 I.S. devices have zero equivalent capacitance and inductance*).

Table 3: Examples of electrical characteristics of cables commonly used in fire protection systems

Cable Type	Core	Size mm ²	Conductor Resistance Ohm/km/Core	Inductance mH / km	Capacitance μF / km		Sheath Resistance Ohm / km
					Core to Core	Core to Sheath	
MICC Pyrotenax Light Duty	2	1.5	12.1	0.534	0.19	0.21	2.77
MICC Pyrotenax Heavy Duty	2	1.5	12.1	0.643	0.13	0.17	1.58
Pirelli FP200	all	1.5	12.1	-	0.08	0.15	-
PVC Sheathed and Insulated to BS 6004	all	1.5	12.1	0.77	0.09	-	-

Table 4: Limits for energy stored in cables

Group	Capacitance μF	Inductance mH	L/R Ratio μH / Ohm
IIC	0.083	4.2	55
IIB	0.65	12.6	165
IIA	2.15	33.6	440

Safety earth

Shunt zener safety barriers must be connected to a high integrity earth by at least one and preferably two copper cables, each of cross sectional area of four mm² or greater. The connection must be such that the impedance from the connection point to the main power system earth is less than one ohm.

Intrinsically safe circuits in the hazardous area should be insulated from earth and must be capable of withstanding a 500V RMS ac test voltage for at least one minute. When using armoured or copper sheathed cables, the armour or sheath is normally isolated from the safe area busbar.

Remote LED connection

A drive point is provided on each of the XP95 I.S. detectors for a remote LED indicator. For connection details see Figure 3. The indicator must be a standard high-efficiency red LED and does not require a series limiting resistor since current is limited within the detector to approximately 1 mA. The remote LED cannot, as in the standard XP95 range, be controlled independently from the integral LED since it is effectively connected in series with the integral LED. The benefit of this configuration is that illumination of the remote LED does not increase the current drawn from the loop.

The system certification allows for the use of any LED indicator having a surface area between 20 mm² and 10 cm² which covers all commonly used case styles from T1 (3 mm) upwards but would exclude some miniature and surface mounted types. Additional requirements of the certification are that the LED and its terminations must be afforded a degree of protection of at least IP20 and must be segregated from other circuits and conductors as defined in BS EN 60079-14.

The Apollo MiniDisc Remote Indicator (53832-070) is suitable using connections B(+) and C(-).

Installation

It is important that the XP95 I.S. detectors are installed in such a way that all terminals and connections are protected to at least IP20 when the detector is in the base. Special care must be taken with the rear of the mounting base where live metal parts (rivets) may be accessible. Flush mounting of the base on a flat surface will provide the required degree of protection.

If the base is mounted on a conduit box (e.g. BESA box or similar) whose diameter is less than 85 mm then the base should be fitted with a XP95 Backplate (Apollo part number 45681-233). Use of the backplate will prevent access to the metal parts and will also protect the rear of the base from water ingress. The conduit box available from Apollo, part no. 45681-204, is also acceptable for mounting I.S. bases. Apollo also supply a range of deckhead mounting boxes.

Figure 4 shows permissible methods of installing intrinsically safe detector bases.

Note: The earth terminal in the base is provided for convenience where continuity of a cable sheath or similar is required. It is not necessary for the correct operation of the detector nor is it provided as a termination point for a safety earth.

Figure 4: Permissible methods of mounting I.S. detector bases

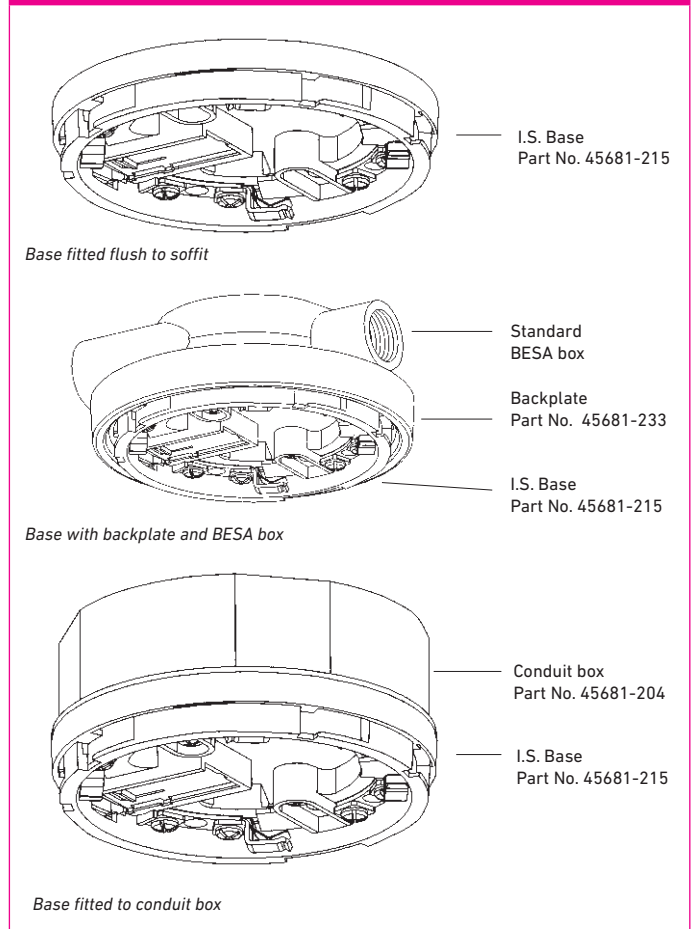

Maximum loading of an I.S. circuit

The safety barrier is a mandatory part of an I.S. system, but the high series impedance limits the number of I.S. detectors that may be fitted to the circuit. Typically an I.S. circuit will have a maximum load of about 15 detectors depending on the barrier type, the type of devices fitted and the number of detector LEDs allowed to illuminate concurrently by the Control and Indicating Equipment.

When calculating the detector load to ensure the I.S. detection zone is not overloaded two components of the current drain must be considered, namely the standing current of the devices by themselves and the maximum drain caused by alarm LEDs being illuminated.

The standing current of the devices can be calculated by taking the sum of the individual device currents on the circuit, as given in the section 'Technical data' for each product.

The maximum number of LEDs that can be illuminated simultaneously should be limited by the panel software.

Table 5 and Table 6 show the maximum device current which can be supported for varying numbers of LEDs illuminated for zener and galvanic barriers respectively.

Table 5: Maximum loading 28 V/300 Ω single channel barrier

Max. No of LEDs illuminated	Max. (Total) device load (mA)
0	8.0
1	7.0
2	6.0
3	5.0
4	4.0
5	3.0

Table 6: Maximum loading 28 V Galvanic Isolator Single Channel Barrier

Max. No of LEDs illuminated	Max. (Total) device load (mA)
0	4.0
1	3.0
2	2.0

Table 7: Loading of the fire loop from a Translator and Barrier pair

	Characteristic	Zener Barrier	Galvanic Barrier
Min Loading	Current (mA)	1	5
	Capacitance (nF)	1	90
Max Loading	Current (mA)	10	10
	Capacitance (nF)	80	170

Using Galvanically Isolated Barriers

Whilst the cable parameters in Table 4 specify the allowable limits for energy storage in the Hazardous area wiring these values do not generally allow reliable XP95 protocol transmission. This is particularly true when using Galvanically Isolated Barriers. Due to their design, these barriers present a relatively high capacitive load on the main fire loop. Therefore, the main fire loop capacitive loading and the I.S. spur capacitive loading must be carefully considered when designing a fire system.

The maximum impedance allowed on the I.S. spur is 15 ohms and 80nF, which is typical of 500m of FP200 cable.

The maximum capacitive load that can be tolerated on the fire loop will be defined by the Control Panel manufacturer. The capacitive load of the IS zone includes 90nF for the galvanic barrier and the total cable capacitance (80nF maximum). This should be added to the main fire loop capacitance and compared with the fire panel specification.

Additionally, a galvanic barrier will add 5mA to the system load which should be added to the loop loading calculations.

The loop calculations for each I.S spur often use the maximum load of 10mA and 200nF as the equivalent load on the fire main loop. Any calculation must ensure that the translator has at least 19V at the translator input.

Servicing

Servicing of I.S. fire detectors may be carried out only by a BASEEFA authorised body. In practical terms this means that Apollo XP95 I.S. fire detectors may be serviced only by Apollo at its factory. Servicing of the fire protection system should be carried out as recommended by the code of practice BS 5839-1 or other local regulations in force. For more information on servicing Apollo detectors, please refer to the care, service and maintenance guide, PP2055.

Approvals

XP95 I.S. detectors have been approved by LPCB to EN54 and the XP95 I.S. Manual Call Point, Part No 55100-940, is LPCB approved to EN54-11. These products have also been approved for marine use by the following bodies:

- American Bureau of Shipping
- Bureau Veritas
- DNV GL
- Lloyds Register of Shipping
- China Classification Society
- Korean Register of Shipping

Details of approvals held are available on request.

The product certification technical files for the XP95 I.S. range are held by BASEEFA in accordance with the requirements of the ATEX Directive 2014/34/EU. All detectors and manual call points are  marked.

Figure 5: Functional earthing and wiring (Sheathed and Unsheathed)

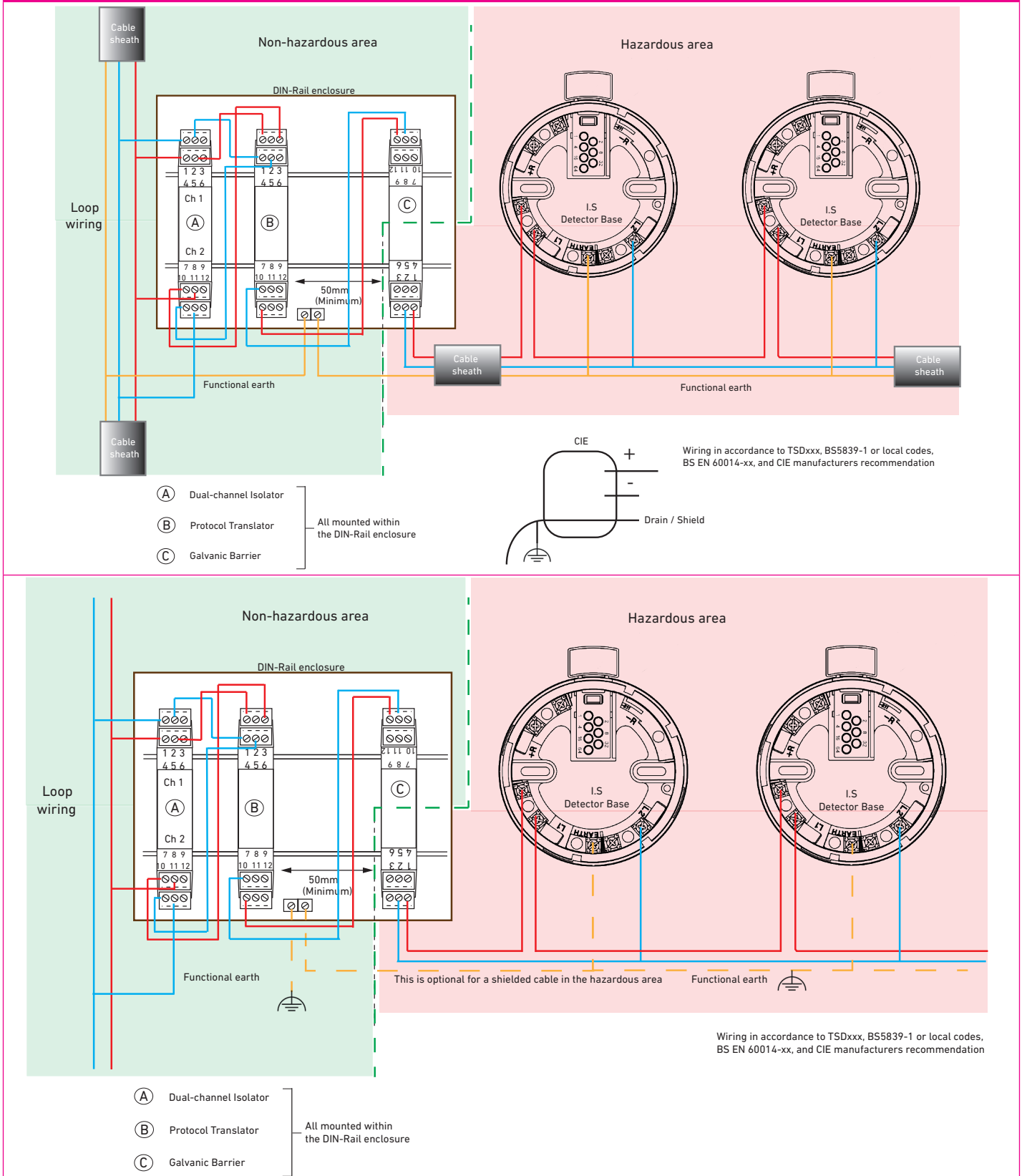
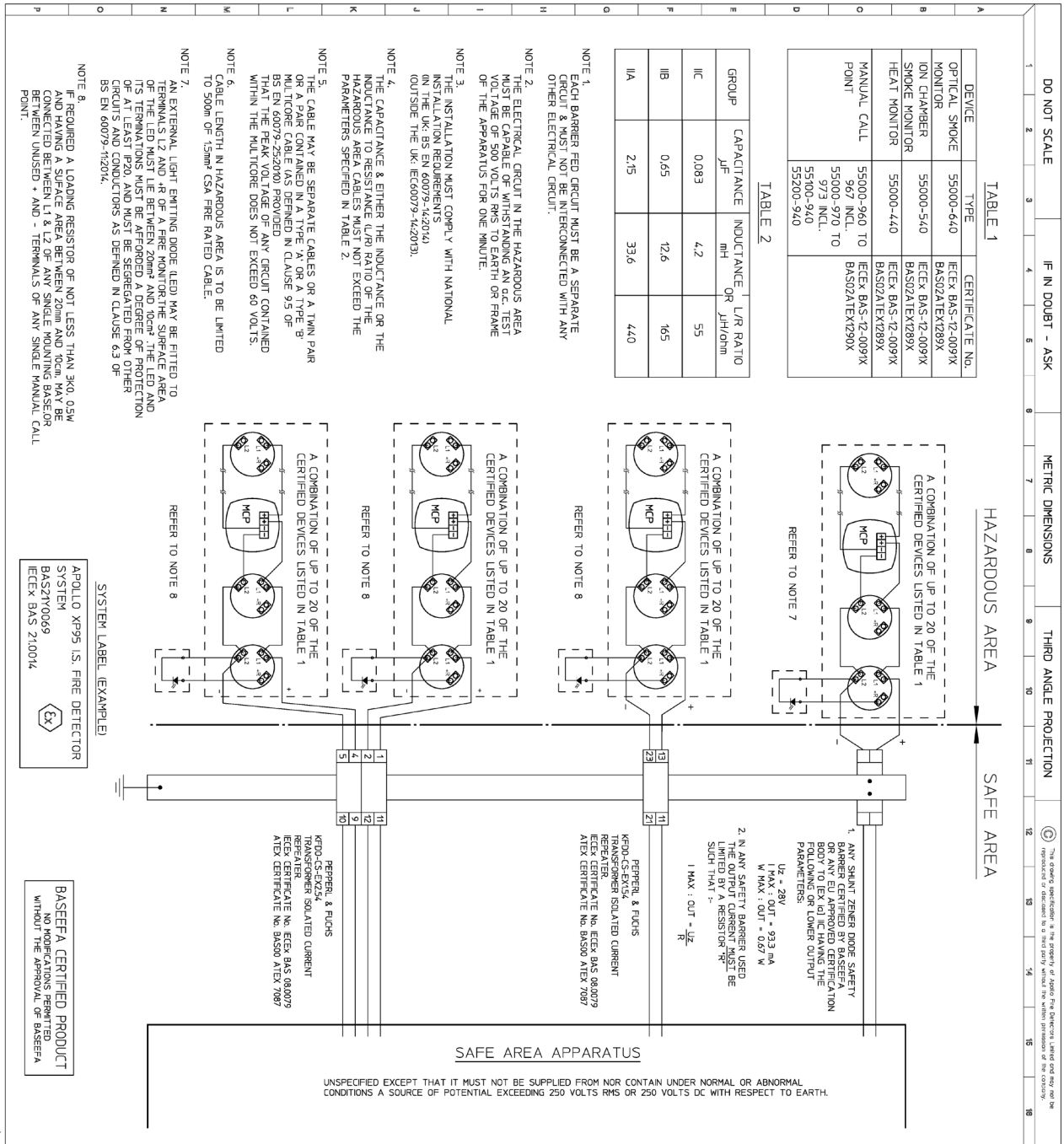

Figure 6: XP95 I.S. System drawing



ISS.	MOD.	DCN. NO.	CHANGE DATE AND SIGNATURE
1	-	A1340	INTRODUCTION
2	-	A1444	SHEET 7 ADDED TO ACCORDANT ORIGINAL DRAWING 395-SC-1
3	-	A1444	DESIGN FROM 7/25 KOS
4	-	A1444	TABLE 1 ADDED TO INTRODUCTIVE ADDENDUM 2/26/2015
5	-	A1444	ADDED TO MEET NEW APPROVAL REQUIREMENTS. R027 DC
6	-	G0075	DEVELOPMENT OF NEW APPROVALS FOR IIA
6A	-	G0075	SYSTEM LABEL BOX & SAFE AREA OCT 19 2018

DESIGN APPROVED	DATE SIGNED	TITLE
ASANDERS	18/08/2018	XP95 INTRINSICALLY SAFE SYSTEM DRAWING.
ASANDERS	18/08/2018	DRG. NO. Z20982

DESIGN APPROVED	DATE SIGNED	TITLE
ASANDERS	18/08/2018	XP95 INTRINSICALLY SAFE SYSTEM DRAWING.
ASANDERS	18/08/2018	DRG. NO. Z20982



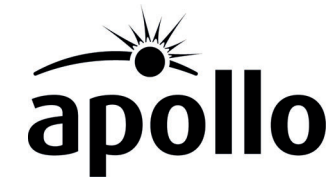

Intrinsically Safe (IS) Products ATEX 2014/34/EU and IECEx Installation Guide

General

All Apollo IS devices are intended for use in hazardous area systems complying with the European ATEX directive 2014/34/EU that deals with products used in hazardous areas. All such systems must incorporate a certified safety barrier or interface to limit the voltage and power to the circuit. Information on suitable barriers and interfaces can be obtained from Apollo.

These notes are intended to supplement the mandatory requirements of the ATEX directive or other applicable regulations. They should not be taken as full instructions for the design and installation of intrinsically safe systems. These activities must be carried out only by qualified personnel.

Certification

The XP95 IS range of detectors and manual call points (MCPs) and the Orbis IS range of detectors are BASEEFA certified as components. Their component certification allows them to be used in certified intrinsically safe systems.

Each product range is covered by a system certificate issued by BASEEFA in Apollo's name. Systems installed according to Apollo system drawings will be covered by the system certification. The use of barriers, interfaces, or other components not included in the system drawing will invalidate the certification.

The system certificate number must be marked on the installed system, preferably on the barrier or interface housing. The system is certified to ATEX only.

Explosion Protection Category

Apollo XP95 IS Heat detectors and call points comply with the categories:

II IG Ex ia IIC T5 -20°C ≤ Ta ≤ 45°C (T4 ≤ 60°C) Ga

Apollo XP95 IS Optical detectors comply with the categories:

II IG Ex ia IIC T5 -20°C ≤ Ta ≤ 55°C (T4 ≤ 60°C) Ga

Orbis IS detector categories are:

II IG Ex ia IIC T5 -50°C ≤ Ta ≤ 40°C (T4 ≤ 60°C) Ga

The ATEX EC type examination certificate numbers applicable to Apollo IS devices are given in the table below:

ATEX Certificate	Apollo Product
BAS02ATEX 1289X	XP95 IS Detectors
BAS02ATEX 1290X	XP95 IS Call Points
Baseefa 06 ATEX 0007X	Orbis Detectors
IECEX Certificate	
IECEX BAS 12.0091X	XP95 IS Detectors
IECEX BAS 12.0091X	XP95 IS Call Points
IECEX BAS 06.0002X	Orbis Detectors

Copies of all component and system certificates, and system drawings are available from Apollo on request.

Installation of Detectors

Detectors must be fitted to certified IS bases. Use of any other bases will invalidate the detector certification. Orbis detectors may be fitted to Series 60 systems using an Orbis IS base adaptor.

The bases must be installed in such a way that all wiring is protected to at least IP20. This requirement will be met if bases are flush mounted. If bases are mounted on BESA boxes, or other boxes having a diameter less than 85mm, they should be fitted with XP95 backplates (Apollo part number 45681-233).

Remote LED indicators may be fitted to Orbis or to XP95 detectors. The LEDs need not be certified but should be either 3mm or 5mm in diameter. The LED terminations must be protected to at least IP20 and the circuits must be segregated from other circuits.

Special Conditions for Safe Use

To avoid problems with electrostatic charging of the enclosure, the equipment must not be located in a dust-laden airflow or cleaned with a dry cloth or with solvents.

Installation of Manual Call Points

Manual call points must be installed to comply with the requirements of the ATEX directive or another applicable code of regulations. All unused cable entry ports must be sealed using suitable stopping plugs to give the required level of ingress protection.

Dust Cover

To ensure optimal performance, leave the dust cover on the product and remove on commissioning.

Further Information

For further information see Apollo publications PP1095 for the XP95 ranges respectively. For information on Orbis see publication PP2250.

Please use the link below to download the ATEX DoC in various EU Languages.

<http://apollo.ly/kn>

If the required Language is not displayed, please contact Apollo to request it.

Apollo Fire Detectors Ltd Declaration of Conformity under ATEX Directive

Notified Body for EC Type Examination and Production: Fimko 0598, Helsinki, Finland
 Harmonised Standards used: EN60079-0:2018 Electrical Apparatus, Explosive atmospheres. Equipment. General requirements and EN60079-11:2012 Electrical Apparatus, Explosive atmospheres. Equipment protection by intrinsic safety 'i'.

Provisions of the Directive fulfilled by the Equipment:

XP95 Optical: Group II Category 1G Ex ia IIC T5 Ga (-20°C ≤ Ta ≤ +55°C) or Ex ia IIC T4 Ga (-20°C ≤ Ta ≤ 60°C)

XP95 Heat: Group II Category 1G Ex ia IIC T5 Ga (-20°C ≤ Ta ≤ +45°C) or Ex ia IIC T4 Ga (-20°C ≤ Ta ≤ 60°C)
 Orbis: Group II Category 1G Ex ia IIC T4 Ga (-50°C ≤ Ta ≤ +60°C) / T5 (-50°C ≤ Ta ≤ +40°C)

MCP: Group II Category 1G / 1D Ex ia IIC T5 Ga (-20°C ≤ Ta ≤ +45°C) or Ex ia IIC T4 Ga (-20°C ≤ Ta ≤ +60°C) or Ex ia IIC T135°C Da (-20°C ≤ Ta ≤ +60°C)

The products listed below are manufactured at the premises of Apollo Fire Detectors Ltd., 36 Brookside Road, Havant, Hampshire, PO9 1JR, England.

Product Name	Models Covered	EC type Examination Certificate	Derived from Un-configured Platform
Orbis IS	Multisensor	Baseefa06ATEX0007X/5 Issued 22 April 2020	400-OH-00012
Orbis IS	Optical Smoke Detector	Baseefa06ATEX0007X/5 Issued 22 April 2020	400-OP-00013
Orbis IS	Heat Detector A1R /A1S/A2S/BR/BS/CS	Baseefa06ATEX0007X/5 Issued 22 April 2020	400-HT-00011
XP95 IS	Heat Detector 55000-440	BAS02ATEX1289X/10, Issued 19 August 2022, IECEx BAS 12.0091X	
XP95 IS	Optical Smoke Detector 55000-640	BAS02ATEX1289X/10, Issued 19 August 2022, IECEx BAS 12.0091X	
XP95 IS MCP	Manual Call Point 55100-940, 55100-942	BAS02ATEX1290X/13, Issued 8 February 2021, IECEx BAS 12.0091X	
XP95 IS MCP	MEDC Manual Call Point 55000-960, 55000-961, 55000-962	BAS02ATEX1290X/13, Issued 8 February 2021, IECEx BAS 12.0091X	
XP95 IS MCP	55200-940	BAS02ATEX1290X/13, Issued 8 February 2021, IECEx BAS 12.0091X	

Directives also applicable: Electromagnetic Compatibility 2014/30/EU; Construction Products Regulations 305/2011/EU; Marine Equipment Directive*, European Directive On Equipment and Protective Systems Intended for the use in Potentially Explosive Atmospheres**.

*This declaration is valid for Directive 96/98/EC as amended by 2015/559 until 17 September 2016

**This declaration is valid for Directive 2014/90/EU from 18 September 2016

***This declaration is valid for Directive 94/9/EC until 19 April 2016

****This declaration is valid for Directive 2014/34/EU from 20 April 2016

This Directive has been enacted into the UK law by the Statutory Instrument No. 1996-192, The Equipment and Protective Systems Intended for the Use in Potentially Explosive Atmospheres Regulations 1996.

This Declaration of Conformity is issued under the sole responsibility of the Manufacturer.

On behalf of the above named company, I declare that, on the date the equipment accompanied by this declaration is placed on the market, the equipment conforms with all technical and regulatory requirements of the above listed directives. Both Principle Engineer, Mr Rob Knight, and Systems Engineer, Mr Mark Schofield, have been designated as the responsible person(s) for the purpose of the Regulations.

 Havant, 19/08/2022
 Mr Rob Knight
 Principle Engineer

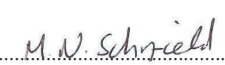
 Havant, 19/08/2022
 Mr Mark Schofield
 Systems Engineer